

JJI-JOISTS TECHNICAL MANUAL

NOVEMBER 2023



**James Jones
& SONS LIMITED**
TIMBER SYSTEMS DIVISION



CONTENTS

Section 1 The JJI-Joist system

The JJI-Joist system.....	4
Engineered wood components.....	5
Design tools and software.....	6
CAD and BIM (Building Information Modelling).....	7
Environmental considerations.....	8

Section 2 JJI-Joists

JJI-Joists.....	10
Introduction.....	11
JJI-Joist properties.....	12
Service holes.....	13
Acoustics.....	14
Fire and durability.....	15
Health and safety.....	16
Site storage and restrictions.....	17

Section 3 Glulam and LVL

Glulam and LVL.....	18
Glulam introduction and properties.....	19
JJLVL-Beam and JJLVL-Rim point loads and UDL.....	20
Glulam and LVL site storage, durability and holes.....	21
Glulam and LVL fixing details.....	22

Section 4 Floor design

Floor design.....	26
Domestic floor span tables.....	28
F-Details.....	29

Section 5 Roof design

Roof design.....	38
Design considerations.....	39
Span tables - flat roof.....	41
Span tables - pitched roof.....	42
R-Details.....	43

Section 6 Wall design

Wall design.....	46
Design considerations.....	47
Thermal performance.....	48
W-Details.....	49

Whilst every effort was made to ensure the accuracy of this publication at the time of printing, James Jones and Sons cannot be held responsible for changes to Building Regulations, NHBC Standards etc. For the most up-to-date information please visit our website: www.jamesjones.co.uk



To view our online CPD please visit The Building Academy. Please click the logo or scan the QR Code.

SECTION 1

THE JJI-JOIST SYSTEM



Russwood offices-Newtonmore

The JJI-Joist system is available from a network of authorised Distributors throughout the UK and Ireland, who offer an estimating and design service inclusive of JJI-Joist layout plans, engineering calculations and material costings. For the most up-to-date authorised Distributor information click [here](#)

ENGINEERED WOOD COMPONENTS

JJI-Joists

A JJI-Joist is a composite engineered timber joist combining 45mm deep high-grade finger jointed softwood flanges with a 9mm thick oriented strand board web. Four flange widths are available; 47, 63, 72 and 97mm wide. Using advanced technology these components are combined to produce an innovative alternative to conventional construction timber with many advantages. JJI-Joists are produced, in the UK to UK preferred dimensions.

The workhorse of the system, the JJI-Joist is a versatile light weight structural member ideal for floor joists, rafters, purlins and wall studs.



Image © Forestry Commission offices-Inverness

Glulam

Glued laminated timber (Glulam) is a high strength and stiffness beam product that is an ideal choice for demanding applications and heavily loaded members.



JJLVL

Laminated Veneer Lumber (LVL) is an advanced wood product suitable for a wide range of structural applications.



Metalwork

James Jones and Sons continues to work closely with the UK's leading engineered timber connector manufacturers. Only connectors approved by James Jones and Sons should be used within our system. All connectors are available from JJI-Joist Distributors as part of the JJI-Joists system offer.



www.itwcp.com



www.strongtie.co.uk

Design tools

Efficiency of design, manufacturing and on-site installation is key to the success of the JJI-Joist system. Through the development of our own design and optimisation software and its integration with external design and manufacturing software, we continue to remain at the forefront of industry innovation and the push for system integration for both traditional and offsite construction.

Software

The JJI-Joist system is fully supported by three Windows™ based software packages written in the UK. These provide the design professional with fast and cost effective design solutions for today's construction industry.

JoistMaster

JoistMaster is a powerful beam design tool for specification and cost analysis. To request the link to download our JoistMaster software please email jjj-joists@jamesjones.co.uk

JoistMaster is a single member design program that is available for free and is aimed at a wide range of user abilities from professional Structural or Civil Engineers and Architects, to students and individuals interested in self-build. JoistMaster produces detailed calculation output that is comprehensive and formatted for submission to Building Control and other interested parties.

JJI Design and OptiMaster

JJI Design and OptiMaster are for use by our national network of trained JJI-Joist Distributors.

JJI Design is a computer aided design program capable of producing fully detailed JJI-Joist layout drawings for architectural approval and joist installation on site. JJI Design is not available to the general public due of the level of training required, but by passing your design queries onto one of our approved Distributors they can use it to quickly generate the best design solution for your project.

The output from JJI Design can be exported to OptiMaster, our stock optimisation program, to allow the Distributor to maximise their cutting efficiency and therefore offer you the best possible solution.

JoistMaster

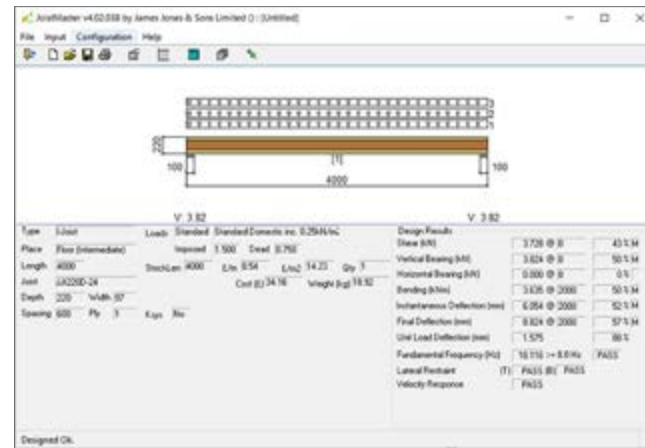

JJI DESIGN

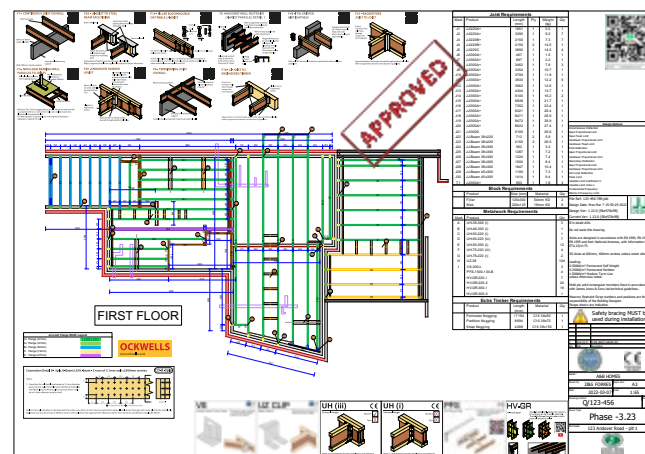

OptiMaster

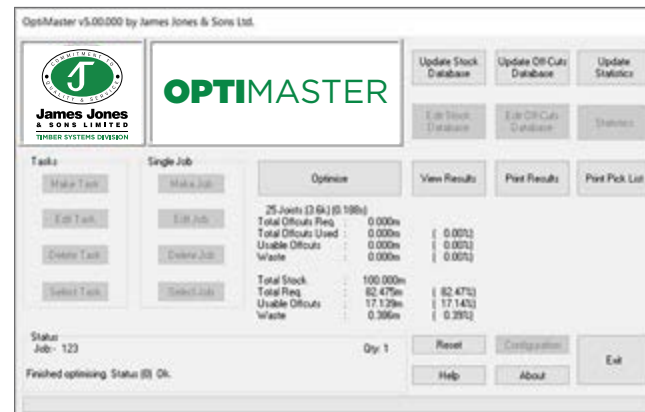

The James Jones and Sons software is fully integratable into the latest industry design software allowing both the import and export of design files. We currently export complete joist layouts in compliance with BIM level 2. For more information please contact James Jones and Sons Ltd.

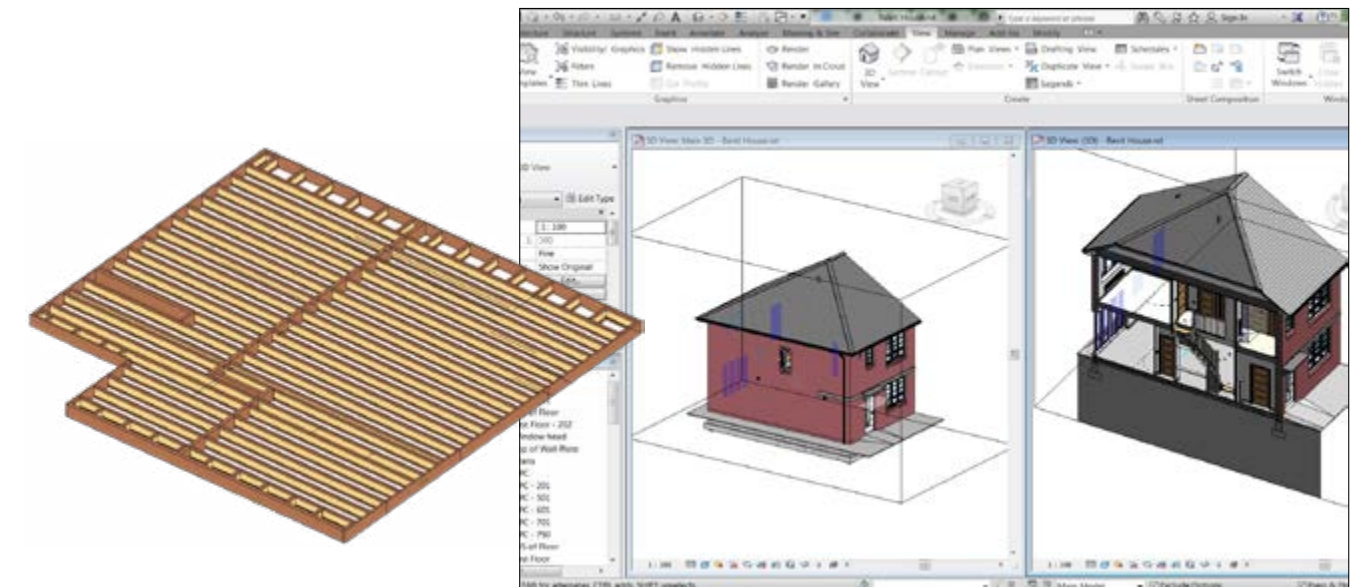
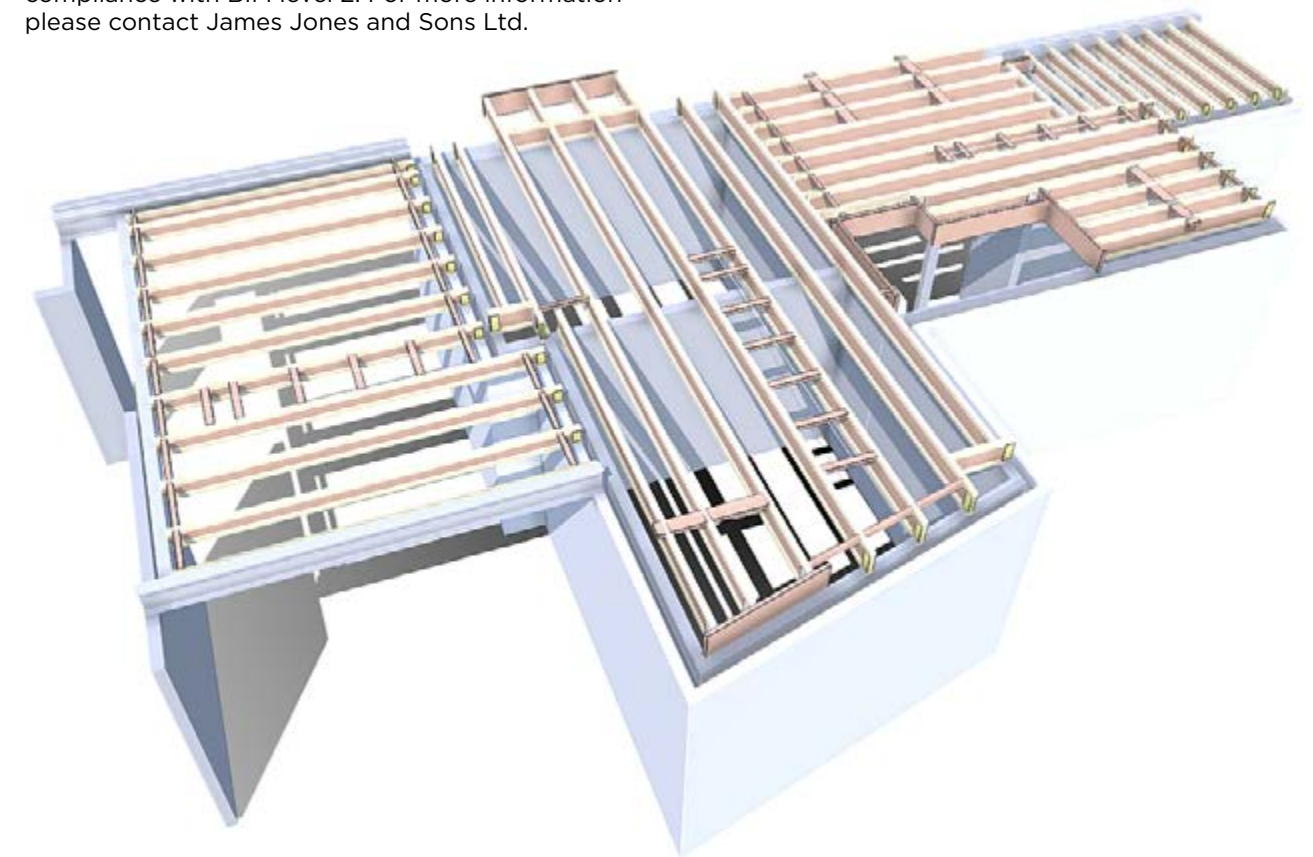

ENVIRONMENTAL CONSIDERATIONS

Environmental considerations

Environmental considerations are a critical factor in the production of JJI-Joists.

James Jones and Sons Ltd (JJSL) is committed to manage their impacts, purchasing sustainable timber, meet government requirements on carbon neutrality and provide independently verified environmental information for our clients.

ISO 14001

Our Environmental Management System (EMS) complies with ISO 14001:2015. It provides assurance to our customers that we meet all current and forthcoming environmental legislation enabling us to manage and continually improve our environmental performance targeting key areas to quantify and reduce our impacts on the environment.

Sustainable timber sourcing

Sustainable timber supply has always been integral to the manufacture of our engineered wood products. All timber products are sourced from sustainable sources complying with the UK government timber sustainability policy and internationally recognised chain of custody schemes. All product claims are independently verified by a certification body on an on-going basis.

Carbon neutrality

International experts and policy makers have stated that there is overwhelming evidence to substantiate a link between climate change and increasing man-made Greenhouse Gas (GHG) emissions. As a result, legislators have committed to a progressive planned reduction in GHG emissions until achieving net zero in order to reduce the negative effects of climate change. Organisations will be expected to progressively reduce all GHG emissions from activities under their direct control in addition to emissions created by their supply chain and product delivery.

JJSL is committed to meet and exceed where possible sectorial and governmental GHG emissions reduction targets through the progressive substitution of fossil fuels with renewable sources (i.e., biomass heat, green electricity, electric vehicles) and the development of supply chain partnerships to reduce GHG emissions from raw materials, production and transport.

JJSL has invested in the creation of new afforestation projects within the UK, which are accredited under the UK Woodland Carbon Code which contributes to mitigate GHG emissions. Trees are the most promising source of GHGs removal as they can convert GHGs such as carbon dioxide (CO₂) present in the atmosphere into wood using photosynthesis. JJSL has also invested in the creation of a windfarm which produces renewable energy reducing society reliance on fossil fuels.

Environmental Product Declaration (EPD)

JJSL is committed to provide meaningful and independently verified environmental information relating to JJI-Joist impacts and sequestered carbon for our clients.

JJSL has completed an Environmental Product Declaration (EPD) for our JJI-Joists which is a voluntary assessment document offering quantified information over a range of environmental impacts (e.g., GHG emissions, acidification potential, energy, water usage) and embedded GHG emissions. These impacts were analysed using a Life Cycle Assessment (LCA) methodology following internationally recognised standards. All claims were independently reviewed by experts which makes them more robust to stakeholder criticism.

LCA has been integrated within our ISO 14001 certified EMS to monitor and identify areas that could be improved within the sourcing, transport and manufacture of our product (i.e. from the forest to end user). Improved supply and delivery logistics, substitution of fossil fuels and more efficient and innovative raw materials are examples of targeted and improved areas within our business.

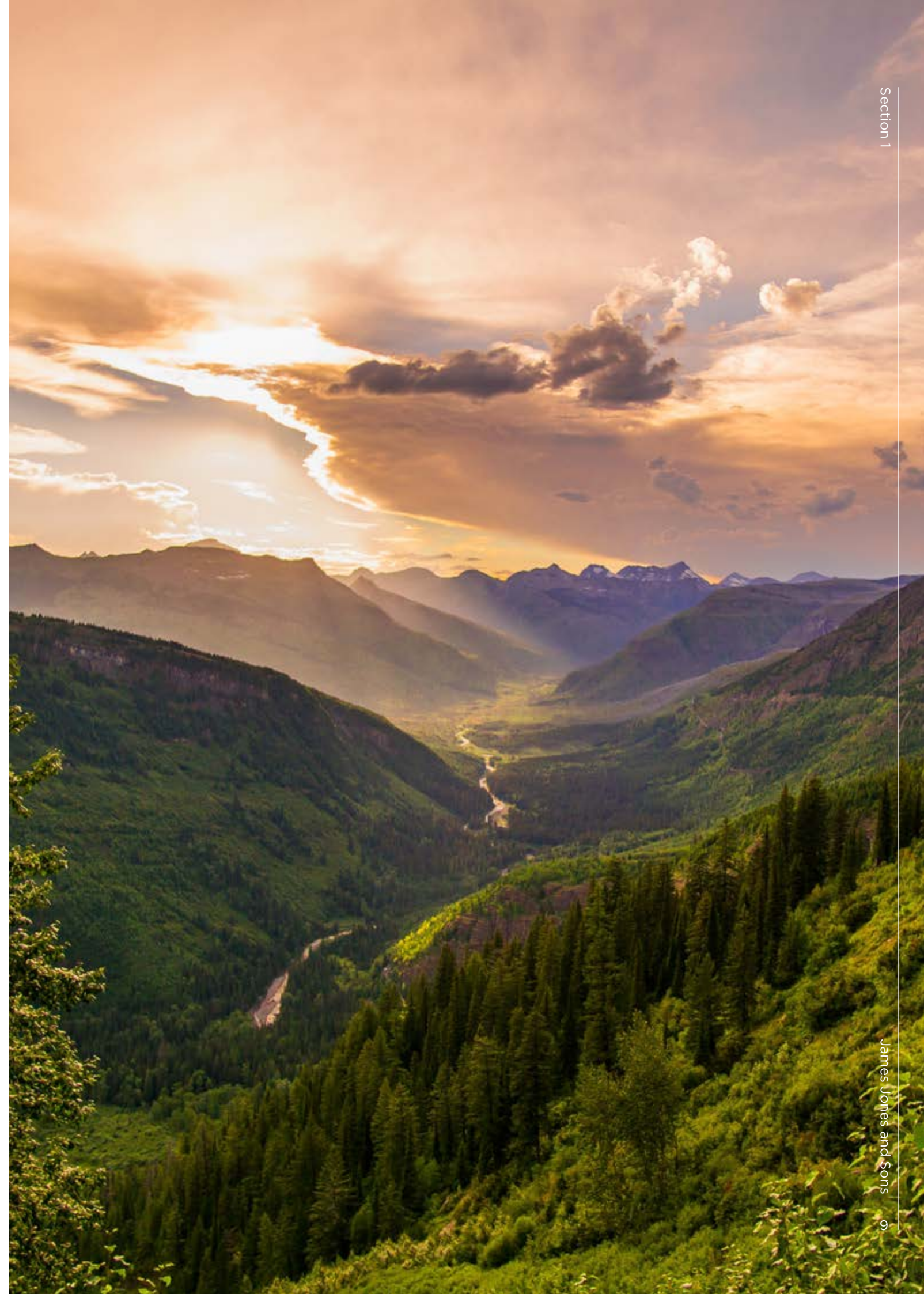

SECTION 2 JJJ-JOISTS



Ruswood offices-Newtonmore

The JJI-Joist is a composite engineered timber joist, combining 45mm deep high-grade finger jointed softwood flanges with 9mm Oriented Strand Board (OSB/3) web.

INTRODUCTION

JJI-Joist composition

The JJI-Joist relies on a unique combination of engineered products designed to complement each other and deliver an outstanding performance. These materials have different specific properties and by combining materials in this way to form a composite section you can use the strengths of each material where it is needed most. This results in the new section outperforming the individual materials that it is made from (the sum is greater than its parts) making it more structurally efficient.

Using advanced technology these components are combined to produce an innovative alternative to conventional construction timber with many additional advantages.

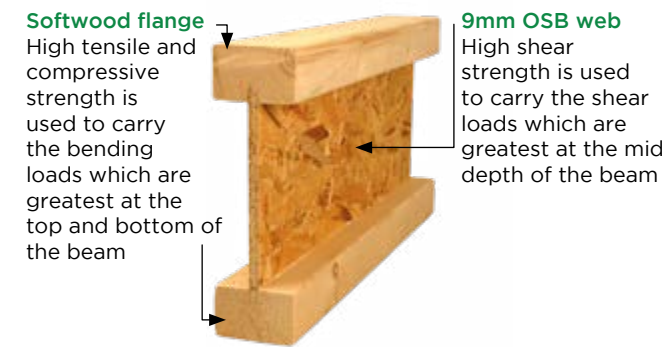

JJI-Joist flange sizes

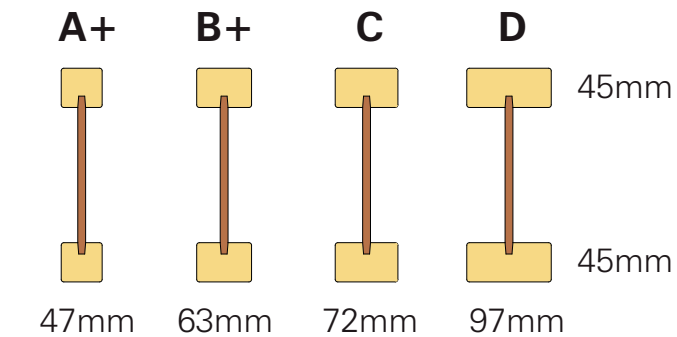

JJI-Joist identification and marking

For onsite identification and traceability, all JJI-Joists are clearly marked with product and manufacturing information. The large markings on the OSB web detail the joist depth, flange size, manufacturing time/date and ETA product approval. Further information printed on the timber flange detail the timber strength class, chain of custody confirmation and a warning 'DO NOT CUT FLANGES'.

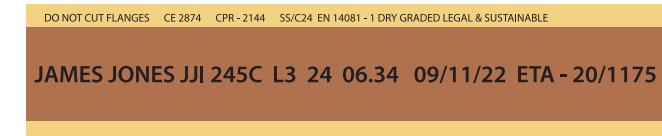

Advantages

JJI-Joists are designed to give a superior strength to weight ratio when compared to traditional solid timber this enables the manufacture of longer and lighter structural members. The JJI-Joist, with a softwood flange:

- Is capable of spanning longer distances
- Is easier to handle
- Is easier to fix and nail
- Is less prone to splitting
- Is quicker to install
- Is extremely stable
- Reduces building maintenance
- Provides a less complex design solution
- Is simple to specify using product specific software
- Has Part E compliant details available
- Is FSC or PEFC accredited
- Has very low embodied energy
- Has independently assured carbon accounting to our Environmental Product Declaration (EPD)

JJI-Joist product range

JJI-Joists are available in a comprehensive range of sizes, designed specifically for the UK market.

Joist Depth mm	JJJ-Joist Product Range UK			
	Flange sizes in mm			
	A+ 47	B+ 63	C 72	D 97
195	✓	-	-	-
220	✓	✓	✓	✓
235	✓	✓	✓	✓
240	✓	✓	✓	✓
245	✓	✓	✓	✓
300	✓	✓	✓	✓
350	-	-	-	✓
400	-	-	-	✓
450	-	-	-	-

Table 1. JJI-Joist product range

Notes for Table 1:

- ✓ Standard JJI-Joist product
- JJI-Joists available in long lengths up to 13.2m
- Non-standard JJI-Joist product. Availability based on minimum order quantity and may incur increased lead times-check with your JJI-Joist Distributor

JJI-Joist properties

Characteristic capacities and advice on choosing the appropriate partial factors for Eurocode 5 design can be found in our ETA 20/1175.

Joist Type	Depth	Bending moment capacity	Bending stiffness	Shear strength capacity	Shear stiffness	Intermediate bearing capacity - minimum 89mm bearing length		End bearing capacity - minimum 45mm bearing length		End bearing capacity - minimum 89mm bearing length		Weight per metre length
		M	EI	V	GA	N/S	W/S	N/S	W/S	N/S	W/S	
	(mm)	(kNm)	(10 ⁹ Nmm ²)	(kN)	(10 ⁶ N)	(kN)	(kN)	(kN)	(kN)	(kN)	(kN)	(kg/m)
JJI 195 A+	195	5.67	305.1	10.64	1.234	16.37	16.37	8.50	8.50	10.33	10.76	2.56
JJI 195 B+		7.20	424.7	11.82	1.234	21.94	21.94	11.39	11.39	13.18	14.42	3.21
JJI 195 C		8.03	505.6	12.44	1.234	25.07	25.07	12.90	13.02	13.18	16.48	3.57
JJI 195 D		10.22	740.5	14.06	1.234	26.66	30.00	12.90	17.54	13.18	22.20	4.58
JJI 220 A+	220	6.60	407.4	11.33	1.477	16.37	16.37	8.50	8.50	10.33	10.76	2.70
JJI 220 B+		8.37	588.5	12.48	1.477	21.94	21.94	11.39	11.39	13.18	14.42	3.35
JJI 220 C		9.32	667.3	13.09	1.477	25.07	25.07	12.90	13.02	13.18	16.48	3.72
JJI 220 D		11.86	941.3	14.71	1.477	26.66	30.00	12.90	17.54	13.18	22.20	4.73
JJI 235 A+	235	7.17	472.4	11.77	1.623	16.37	16.37	8.50	8.50	10.33	10.76	2.79
JJI 235 B+		9.08	678.1	12.90	1.623	21.94	21.94	11.39	11.39	13.18	14.42	3.44
JJI 235 C		10.11	771.3	13.51	1.623	25.07	25.07	12.90	13.02	13.18	16.48	3.80
JJI 235 D		12.85	1088.0	15.12	1.623	26.66	30.00	12.90	17.54	13.18	22.20	4.82
JJI 240 A+	240	7.35	495.0	11.92	1.671	16.37	16.37	8.50	8.50	10.33	10.76	2.82
JJI 240 B+		9.32	707.6	13.05	1.671	21.94	21.94	11.39	11.39	13.18	14.42	3.47
JJI 240 C		10.37	807.4	13.65	1.671	25.07	25.07	12.90	13.02	13.18	16.48	3.83
JJI 240 D		13.18	1140.8	15.26	1.671	26.66	30.00	12.90	17.54	13.18	22.20	4.85
JJI 245 A+	245	7.54	518.0	12.08	1.720	16.37	16.37	8.50	8.50	10.33	10.76	2.85
JJI 245 B+		9.55	737.2	13.19	1.720	21.94	21.94	11.39	11.39	13.18	14.42	3.50
JJI 245 C		10.64	844.4	13.80	1.720	25.07	25.07	12.90	13.02	13.18	16.48	3.86
JJI 245 D		13.52	1195.4	15.40	1.720	26.66	30.00	12.90	17.54	13.18	22.20	4.87
JJI 300 A+	300	9.67	816.3	13.86	2.255	16.37	16.37	8.50	8.50	10.33	10.76	3.17
JJI 300 B+		12.21	1121.9	14.91	2.255	21.94	21.94	11.39	11.39	12.66	14.42	3.82
JJI 300 C		13.58	1319.5	15.49	2.255	25.07	25.07	12.08	13.02	12.66	16.48	4.18
JJI 300 D		17.22	1899.0	17.07	2.255	26.66	30.00	12.08	17.54	12.66	22.20	5.20
JJI 350 A+	350	11.66	1113.5	15.61	2.741	16.37	16.37	8.50	8.50	9.72	10.76	3.46
JJI 350 B+		14.68	1484.6	16.60	2.741	21.94	21.94	10.22	11.39	9.72	14.42	4.11
JJI 350 C		16.31	1899.6	17.16	2.741	25.07	25.07	10.22	13.02	10.93	16.48	4.48
JJI 350 D		20.65	2647.6	18.70	2.741	26.66	30.00	10.22	17.54	10.93	22.20	5.49
JJI 400 A+	400	13.70	1521.6	17.43	3.227	16.37	16.37	8.20	8.50	9.23	10.76	3.76
JJI 400 B+		17.20	2023.3	18.37	3.227	21.94	21.94	8.20	11.39	9.23	14.42	4.40
JJI 400 C		19.09	2673.0	18.91	3.227	25.07	25.07	8.20	13.02	10.17	16.48	4.77
JJI 400 D		24.12	3428.0	20.41	3.227	25.79	30.00	8.20	17.54	10.17	22.20	5.78
JJI 450 A+	450	15.79	1999.3	19.31	3.713	16.37	16.37	6.79	8.50	9.23	10.76	4.05
JJI 450 B+		19.77	2651.5	20.20	3.713	21.50	21.50	6.79	11.39	9.23	14.42	4.70
JJI 450 C		21.92	3018.4	20.72	3.713	21.50	22.27	6.79	13.02	9.23	16.48	5.06
JJI 450 D		27.64	4170.4	22.18	3.713	21.50	30.00	6.79	17.54	9.23	22.20	6.07

Table 2. Characteristic capacities for JJI-Joists

Notes for Table 2:

- All strength properties are for joists acting as non-systems. For joist acting as a system multiply values by 1.1 ($K_{sys}=1.1$)
- Minimum end bearing length =45mm, minimum intermediate bearing length =89mm
- N/S: No Web Stiffeners required, W/S: Web Stiffeners required
- Lateral buckling checks should be performed during the design of structures using JJI-Joists if both flanges are not fully restrained
- Refer to Table 1 and notes for JJI-Joist availability

JJI Point Load (P) and Uniformly Distributed Load (UDL)

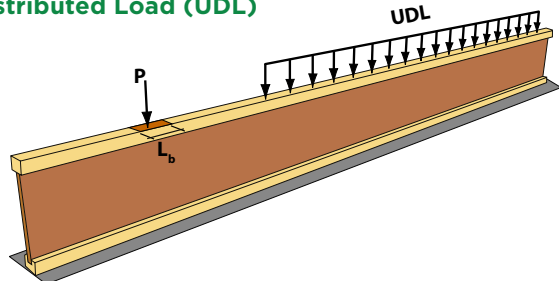

Characteristic JJI-Joist vertical load capacities when fully supported

JJI Joist Depth	Characteristic load per metre run (kN/m)
195	75.0
220	75.0
235	71.0
240	69.0
245	64.0
300	60.0
350	41.0
400	32.0
450	31.0

Table 3. JJI-Joist vertical loads

Notes for Table 3:

- Values for point load can be calculated as $P=UDL \times (L_b + 60)/1000$ where L_b is the contact length of the load applied in mm
- The beam is considered fully restrained, effects of buckling have been ignored
- Allowance may be made for load spreading of sole plates and bottom rails at the designers discretion

JJI-Joist hole installation guide

Service holes **MUST NOT BE CUT** in the JJI-Joist flange.

The maximum size of a service hole that can be cut in the web of a JJI-Joist at a particular location depends on the specific load configuration applied to the joist. The table below gives the minimum required distance, L (mm), from inside face of support to the nearest edge of a hole for uniformly loaded, simply supported

joists under standard domestic loading of 0.75kN/m² dead load (including partition allowance) and 1.5kN/m² imposed load for JJI-Joists up to 600mm centres. For loads, holes and joist spans not covered by this table please assess using our JoistMaster software or contact your Distributor.

Joist Depth (mm)	Joist Span (mm)	Hole Size (mm)													
		50		75		100		125		150		175		200	
		○ + ◻	◻	○ + ◻	◻	○ + ◻	◻	○ + ◻	◻	○ + ◻	◻	○ + ◻	◻	○ + ◻	◻
220	3000	300	300	361	656	721	838	838	1159						
	3500	300	300	500	824	895	1024	1024	1375						
	4000	300	310	651	1001	1078	1216	1216	1596						
	4500	300	449	813	1186	1268	1415	1415	1819						
235	4890	300	566	945	1334	1420	1574	1574	1996						
	3000	300	300	300	566	656	873	873	1217						
	3500	300	300	325	725	824	1062	1062	1440						
	4000	300	300	463	894	1000	1258	1258	1665						
240	4500	300	300	612	1072	1185	1460	1460	1893						
	5066	300	382	794	1282	1402	1693	1693	2154						
	3000	300	300	300	526	623	872	872	1235						
	3500	300	300	300	681	788	1061	1061	1459						
245	4000	300	300	392	847	962	1257	1257	1686						
	4500	300	300	537	1021	1144	1458	1458	1916						
	4711	300	300	601	1097	1223	1544	1544	2013						
	3000	300	300	300	482	586	865	865	1252	955	1252				
300	3500	300	300	300	632	747	1053	1053	1478	1152	1478				
	4000	300	300	317	794	918	1248	1248	1706	1355	1706				
	4500	300	300	457	965	1097	1449	1449	1937	1563	1937				
	5184	300	320	666	1212	1353	1731	1731	2256	1854	2256				
350	4000	300	300	300	300	300	803	803	1308	1230	1542	1477	1883	1572	1883
	4500	300	300	300	300	306	975	975	1513	1430	1762	1693	2126	1795	2126
	5000	300	300	300	300	449	1154	1154	1722	1635	1985	1912	2369	2019	2369
	5500	300	300	300	535	670	1341	1341	1935	1844	2210	2135	2613	2247	2613
5803	300	300	300	687	822	1456	1456	2066	1972	2348	2271	2761	2385	2761	

Table 4. Allowable Locations for Circular, Square and Rectangular Holes (Domestic Applications)

Notes for Table 4:

- Table 4 has been calculated for joists in intermediate domestic floors, including partition allowance ($G_k=0.75kN/m^2$, $q_k=1.5kN/m^2$, $Q_k=2kN$) at 600mm centres
- Where more than one hole is to be cut, the minimum spacing between holes must be 2 times the width of the largest hole
- The rectangular hole width b should not exceed 1.5xD
- Cut all holes carefully, do not overcut and do not cut flanges
- Where holes are required in rim and header joists of timber frame construction refer to the Building Designer
- The bearing support length used for this table is 45mm
- A 35mm hole may be drilled any where on the centre line of the web material provided there is a minimum of 35mm from the edge of the hole to the end of the joist and it is not directly over a support

Service hole diagram

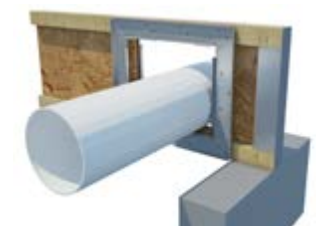
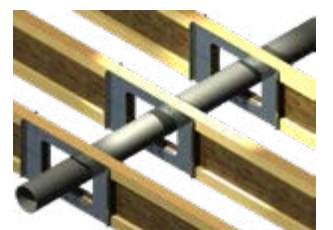
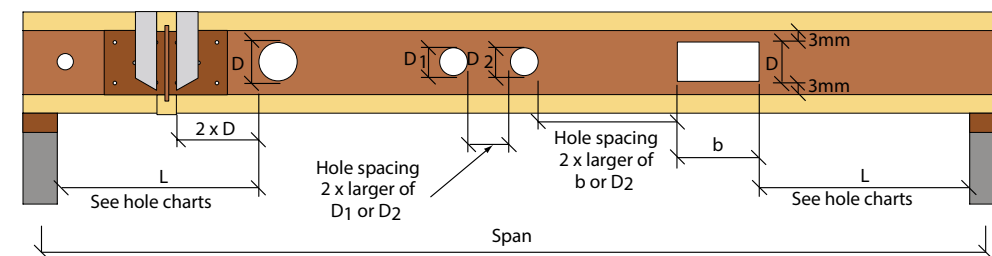

In circumstances where holes are positioned outwith the guidance above, reinforcement plates may be a suitable alternative.

JJI-Joist properties

The transmission of sound between rooms needs to be limited to ensure acceptable levels of noise for the occupants and their neighbours. In the UK the relevant limits are detailed in applicable building regulation documents as detailed below:

- **England and Wales, Building Regulations Part E (Resistance to the Passage of Sound), 2015**
- **Scottish Building Standards, Section 5 (Noise), 2019**

It should be noted that the overall acoustic performance is generally governed by the ceiling, decking and insulation materials within the floor structure, with the structural member (I-Joist) having very limited influence.

James Jones and Sons Ltd have focused on testing the most commonly used materials within floor constructions. For floor constructions that differ from those detailed below we would advise consulting an acoustic specialist. Any combination of material chosen to meet the acoustic requirements should also be checked for compliance with fire requirements (See page 15).

Intermediate floors

The performance of intermediate floors is determined using laboratory tests to ISO717-1.

James Jones and Sons Ltd have undertaken a number of acoustic tests to confirm the performance levels of the following commonly used floor makeups (illustrated below). For further information please refer to Technical Bulletin 14 'Resistance to the Passage of Sound' for use in England and Wales, and Technical Bulletin 38 '44dB Rw Acoustic Performance of 220mm JJI-Joist floor' for use in Scotland.

England and Wales Intermediate Floor

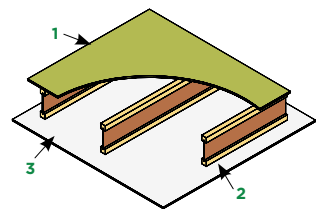

1. Floor Deck - min 18mm flooring grade chipboard
2. Structural Member - min 220mm deep JJI-Joists at a mini 400mm centres
3. Directly applied Ceiling - 15mm gypsum wall board (Also see fire requirements for specification)

Scotland Intermediate Floor

1. 22mm Caberdek P5 chipboard
2. 5mm bead of Caberfix joint and joist adhesive
3. 220mm JJI-Joist
4. 100mm Knauf acoustic roll
5. 15mm Knauf Wallboard (Also see fire requirements for specification)

Separating floor

JJI-Joists can be readily specified for use in separating floors in England and Wales and Scotland. These floors reflect the additional materials required due the increase in acoustic and fire performance of the floor structure.

JJI-Joists in timber frame construction complying with part E1

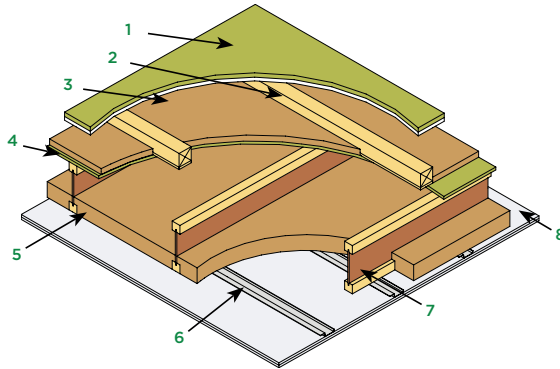

Robust detail E-FT-1

1. 18mm chipboard and 19mm plasterboard plank
2. 70mm dynamic battens at 600mm centres
3. Minimum 25mm quilt between battens
4. Sub-deck board, minimum 15mm
5. 100mm mineral fibre based quilt
6. Resilient bar at 400mm centres
7. Minimum 235mm deep JJI-Joist at centres to suit span
8. 12.5mm plasterboard and 19mm plasterboard plank or 2 no. layers 15mm plasterboard (Also see fire requirements for specification)



There are currently 4 solutions where JJI-Joists can be fully incorporated into the makeup of separating floors to achieve Robust Detail status.

- E-FT-1 (England and Wales Generic solution)
- E-FT-5 (England and Wales Collecta® ScreedBoard® 28)
- E-FT-7* (England and Wales FFT80)
- V-FT-1 (Scotland Generic solution)

For further information www.robustdetails.com/

*Recommended that Building Control be consulted to ensure full compatibility with other NI Regulations and Standards.

General

Successful fire tests have been undertaken on floors using JJI-Joists and there are various solutions available for half hour and one hour fire resistance performance.

JJI-Joists are lightweight structural timber beams and when used in combination with other material components, such as decking/sheathing boards, insulation and ceiling/lining layers, construct a functional element, i.e.. floor, roof or wall.

The overall fire resistance performance of an element is dictated by the general arrangement of all associated components; size, shape, spacing, material specification, fixing details, and the requirement for service penetrations, i.e.. downlighters and ventilation. In general, I-joists require isolation from the initial fire with the use of a non-combustible or limited combustibility board material, such as plasterboard. The correct specification of this layer is vital to achieving the desired level of fire performance.

Fire resistance

The fire resistance of an element is given a standard time rating which is an indication of how long it is expected to function at an acceptable level in a typical fire. There are three specific areas of interest when determining the fire resistance of an element:

1. **Resistance (R):** the element must continue to support the loads for the declared period.
2. **Integrity (E):** the element must prevent the spread of the fire.
3. **Insulation (I):** the element must prevent excessive temperature rises on the unexposed face.

If all three criteria are met for a predefined time, results are reported indicating the fire resistance duration; REI30, REI60.

Note: the actual fire performance may be considerably more than the standard duration times.

Typical Half Hour Detail (REI 30)

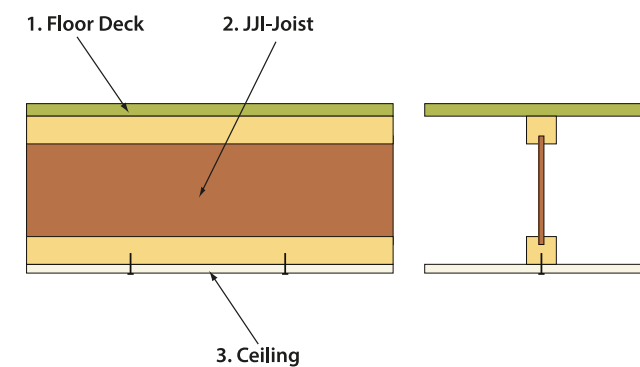

Demonstration of compliance

There are two main methods to demonstrate compliance with a specified fire resistance requirement:

1. **Fire design:** the use of charring rates of timber products along with material data for the other components of an element to conservatively determine the fire resistance performance.

2. **Testing:** elements are tested in a computer-controlled furnace according to either BS476 or EN1365, with the test results report detailing the exact makeup of the element. A fire rating classification report is also generated. Additionally, an assessment can be issued by a qualified Fire Engineer under a strict code of practice and can be used to combine the information of multiple tests or in some cases to further extend the permissible variations.

Building regulations

The fire resistance requirements for elements of a structure are generally dictated by the relevant Building Regulations. Note: no provisions are made for the junctions between elements and there is significant regional variation in the level of information required by local authorities to demonstrate compliance.

Downlighters within JJI-Joist intermediate floors

James Jones and Sons Ltd. have working relationships with several of the UK's leading downlighter manufacturers. For further information, please contact James Jones and Sons Ltd.

Latest information

James Jones and Sons Ltd. is committed to providing the most up to date fire performance information to its customers and is actively engaged in ongoing research and testing in this area. For the most up to date information please contact the technical department.

STA design guide to separating distances during construction

Design guidance is available for new JJI-Joists solutions for category C1 and C2 structures covered under the STA (Structural Timber Association) separating distances during construction. For further information please refer to Technical Bulletin 51 'JJI-Joist fire solutions for use with the STA design guide to separating distances during construction'.

Treatment and durability

JJI-Joists are untreated and when used in a Service Class 1 or 2 environment, the ETA certificate advises that they may be taken to have a service life in excess of 50 years.

Common floor and roof materials dead loads

For JJI-Joist floor and roof applications, the adjacent component dead loads can be used to calculate the overall dead load of the structure. Alternatively contact the product manufacturer for specific weights/loads.

Material	kN/m ²	Material	kN/m ²
18mm Chipboard	0.13	12.5mm Plasterboard	0.09
22mm Chipboard	0.16	15mm Plasterboard	0.11
15mm Plywood	0.10	19mm Plank	0.15
19mm Plywood	0.12	12.5mm Fireboard	0.11
15mm OSB	0.11	5mm Skim Coat	0.05
18mm OSB	0.13	100mm Glass Fibre	0.02
18mm T&G Boards	0.10	100mm Rockwool	0.04
22mm T&G Boards	0.12	Timber Studs with 12.5mm Plasterboard	0.25

Table 5 . Materials dead loads

Temporary erection bracing notes

The builder is responsible for identifying and minimising the risks involved in erecting JJI-Joists to ensure that the health and safety of all workers is maintained. Builders should be aware of the health and safety responsibilities imposed on them by the Construction (Design and Management) Regulations CDM 2015. Proper erection procedures and bracing are vital to the safe construction of JJI-Joists floors. The following notes may assist builders in preparing a safety assessment.

1. Do not allow workers to walk on unbraced joists
2. Do not store building materials on unbraced joists
3. JJI-Joists should be erected straight and vertical. The maximum deviation from horizontal should not exceed 10mm and the maximum deviation from the vertical should not exceed 2mm
4. JJI-Joists are unstable until fully braced. Bracing includes: longitudinal binders, diagonal bracing, stability blocking, rim joist/rim boards

5. All longitudinal binders, diagonal braces, stability blocks, and hangers should be completely installed and fully nailed as detailed
6. Lateral strength should be provided by a diagonally braced and blocked system across at least 3 joists as shown in the Erection Bracing Details (diagram below). Additional braced and blocking systems should be provided at 12m spacing in long joist runs
7. Once a JJI-Joist floor has been fully braced, construction materials may be placed on the floor provided that the overall weight of material to be placed on a single joist does not exceed 250kg (200kg for 195mm deep joists). Please refer to Technical Bulletin 47, 'Loading out JJI-Joist Floors'
8. Flooring should be fully fixed to the JJI-Joists before additional loads are placed on the floor
9. The ends of cantilevers should be stabilised with longitudinal binders fixed to the top and bottom flanges

Installation guidelines

This diagram indicates temporary erection bracing only. It is applicable to both timber frame and masonry construction.

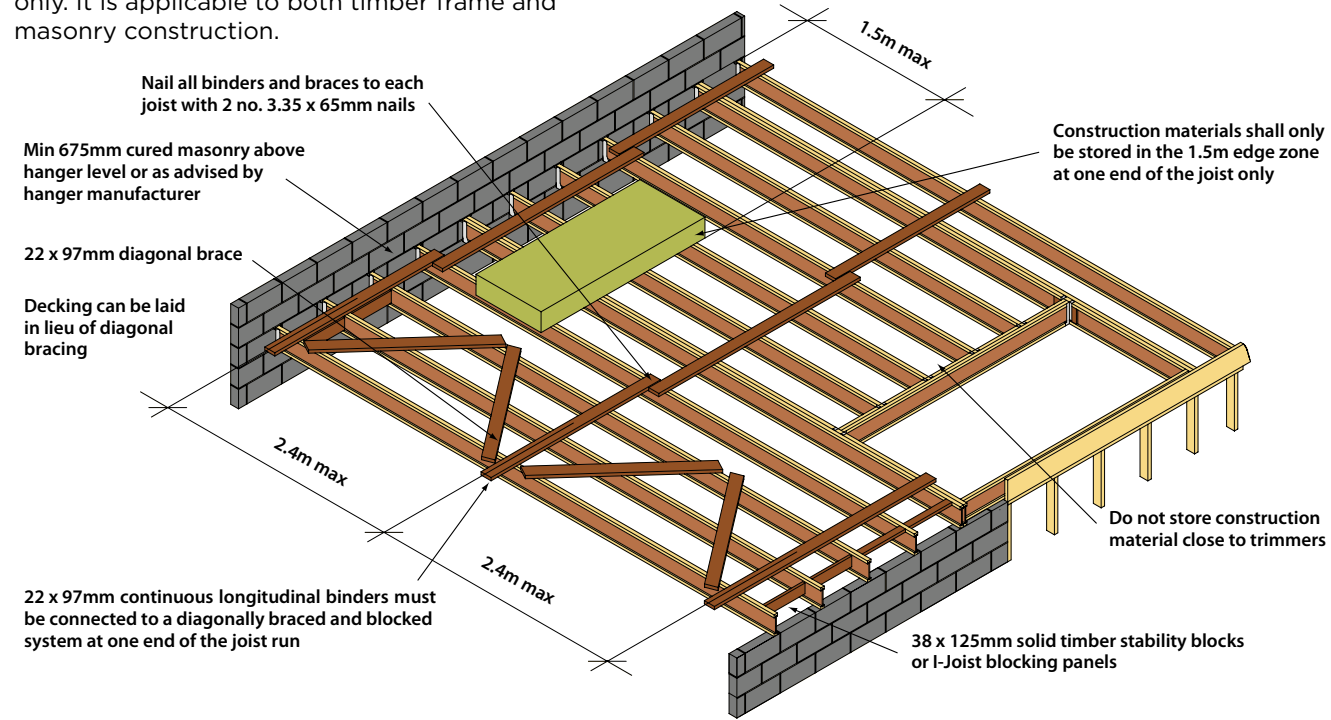

Stability blocking notes

1. Use timber blocks or JJI-Joist blocking pieces
2. Timber blocks to be minimum 38 x 125mm cut squarely and accurately to maintain joist spacing. Fasten with minimum 2 no. 3.35 x 65mm nails
3. Stability blocks need to be fixed to 3 joists and cover a minimum distance of 1.2m
4. Timber blocks in the diagonally braced systems are required in each run of joists and at cantilever supports
5. When joists butt on an interior support, block both sets of joists
6. Additional braced and blocked systems should be provided at 12m spacing in long joist runs

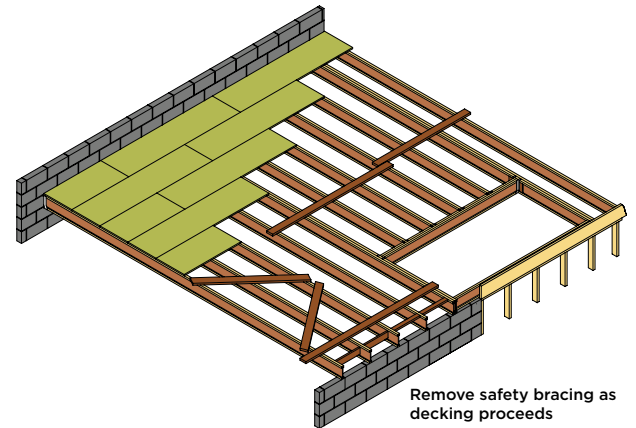

JJI-Joist site storage

ATTENTION! The following conditions are not allowed

Stairwell hatch system

Designed as an alternative to sacrificial stairwell joists, the OCKWELLS Stairwell Hatch System provides a reusable GRP platform over stairwell openings.

For further information click on the logo below.



SECTION 3 GLULAM AND LVL



Asda-Bootle

Glued laminated timber (Glulam) is a high grade beam product that is an ideal choice for high strength and stiffness applications for heavily loaded members. Glulam is readily available in depths to suit the JJI-Joist range.

Laminated Veneer Lumber (LVL) is an advanced wood product suitable for a wide range of structural applications. Available in two specifications; JLV-L-Beam and JLV-L-Rim, LVL is exceptionally strong for the most demanding of applications.

GLULAM INTRODUCTION AND PROPERTIES

Introduction

Glulam is a high specification engineered timber product made by gluing together strength graded timber laminations to make up larger sections and distribute the natural defects evenly throughout the volume. The laminations are finger jointed to allow long lengths to be formed. This results in a structural unit of great strength and dimensional stability. Glulam beams can be produced in a range of sectional sizes and are available from our distribution network in lengths up to 12m.

Typical Glulam sections



Glulam product range

Glulam can be supplied as part of the JJI-Joist system. It is available in depths that match the JJI-Joist range (Table 1) and two standard widths. See table below for standard range.

Intermediate widths can be achieved by fixing multiple sections together with suitably specified fixings.

Section Depth	Width	
	38	45
220	✓	✓
235	✓	✓
245	✓	✓
300	✓	✓
350	-	✓
400	-	✓

Table 6. Glulam product range

Characteristic values for GL28c Glulam

Glulam should be designed to Eurocode 5 and requires the use of characteristic values as shown in Table 7.

Care should be taken to ensure that all partial factors used to convert the characteristic values to design values are correctly chosen for the prevailing design conditions. See tables 9 and 10.

Characteristic Values		Glulam	Units
Bending strength	Edgewise, parallel to grain	$f_{m,k}$	28 N/mm ²
Tension strength	Parallel to grain	$f_{t,0,k}$	19.5 N/mm ²
	Perpendicular to grain edgewise	$f_{t,90,k}$	0.5 N/mm ²
Compression strength	Parallel to grain	$f_{c,0,k}$	24 N/mm ²
	Perpendicular to grain edgewise	$f_{c,90,k}$	2.5 N/mm ²
Shear strength	Edgewise, parallel to grain	$f_{v,k}$	3.5 N/mm ²
Modulus of elasticity	Parallel to grain	$E_{0,mean}$	12,500 N/mm ²
	5% parallel to grain	$E_{0,05}$	10,400 N/mm ²
	Perpendicular to grain edgewise	$E_{90,mean}$	300 N/mm ²
Shear modulus	Edgewise, parallel to grain	G_{mean}	650 N/mm ²
	Edgewise, parallel to grain	$G_{0,05}$	540 N/mm ²
Density	Characteristic	ρ_k	390 kg/m ³
	Mean	ρ_{mean}	420 kg/m ³

Table 7. Characteristic Values for GL28c Glulam

Glulam vertical load characteristic capacities when fully supported

Width	Characteristic load per metre run (kN/m)
38	95
45	112.5

Table 8. GL28c Glulam vertical load characteristic capacities

Notes for Table 8:

- Values for point load can be calculated as $P = UDL \times (L_b + 60) / 1000$ where L_b is the contact length of the load applied in mm
- The beam is considered fully restrained, effects of buckling have been ignored
- Factor $K_{c,90}$ has been taken as 1, however, allowance may be made for load spreading of sole plates and bottom rails at the designers discretion

Glulam point loads (P) and Uniformly Distributed Load (UDL)

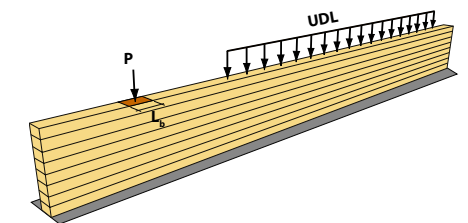

Partial factors for Glulam and LVL

Service Class	Load Duration Class					K_{def}
	Permanent	Long term	Medium term	Short term	Instantaneous	
1	0.60	0.70	0.80	0.90	1.10	0.60
2	0.60	0.70	0.80	0.90	1.10	0.80
3	0.50	0.55	0.65	0.70	0.90	2.00

Table 9. K_{mod} and K_{def} factors for Glulam and JLV-L

Note for Table 9:

- Values provided in BS EN 1995-1-1

Material	γ_M
Glulam	1.25
LVL	1.20

Table 10. γ_M material factors for Glulam and JLV-L

Note for Table 10:

- Values provided in NA to BS EN 1995-1-1

Introduction

Laminated Veneer Lumber (LVL) is an advanced wood product suitable for a wide range of structural applications, from new build to repair. LVL as a material is exceptionally strong with a great load bearing capacity, homogeneous quality and good workability.

JJLVL-Beam and JJLVL-Rim are available in 12m lengths and in a range of sizes.

Typical LVL sections



LVL product range

JJLVL-Beam and JJLVL-Rim can be available in depths to suit the JJI-Joist range (Table 1) and three standard widths depending on the grade. See table below for our standard range.

Care should be taken to ensure that all partial factors used to convert the characteristic values to design values are correctly chosen for the prevailing design conditions. See tables 9 and 10.

Section Depth	Width		
	JJLVL-Rim	JJLVL-Beam	
	30	45	75
220	✓	✓	✓
240	✓	✓	-
245	✓	✓	✓
300	✓	✓	✓
350	-	✓	-
400	-	-	✓

Table 11. LVL product range

Characteristic values for JJLVL-Beam and JJLVL-Rim

JJLVL-Beam and JJLVL-Rim should be designed to Eurocode 5 and requires the use of characteristic values as shown in Table 12.

Characteristic Values			JJLVL-Rim	JJLVL-Beam	Units
Bending strength	Edgewise, parallel to grain	$f_{m,k}$	32	44	N/mm ²
Size effect parameter		s	0.15	0.15	-
Tension strength	Parallel to grain	$f_{t,0,k}$	26	35	N/mm ²
	Perpendicular to grain edgewise	$f_{t,90,k}$	6	0.8	N/mm ²
Compression strength	Parallel to grain	$f_{c,0,k}$	26	35	N/mm ²
	Perpendicular to grain edgewise	$f_{c,90,k}$	9	6	N/mm ²
Shear strength	Edgewise, parallel to grain	$f_{v,k}$	4.5	4.1	N/mm ²
	Parallel to grain	$E_{0,mean}$	10500	13800	N/mm ²
Modulus of elasticity	5% parallel to grain	$E_{0,05}$	8800	11600	N/mm ²
	Perpendicular to grain edgewise	$E_{90,mean}$	2400	ND	N/mm ²
Shear modulus	Edgewise, parallel to grain	G_{mean}	600	600	N/mm ²
	Edgewise, parallel to grain	$G_{0,05}$	400	400	N/mm ²
Density	Characteristic	ρ_{mean}	480	480	kg/m ³
	Mean	ρ_k	510	510	kg/m ³

Table 12. Characteristic Values

Notes for Table 12:

1. ND= Parameter not declared by manufacturer
2. Properties valid for products within 24-75mm thickness
3. Properties declared in certificates 0809-CPR-1203 and 0809-CPR-1214

LVL vertical load characteristic capacities when fully supported

Width [mm]	Characteristic load per metre run (kN/m)	
	JJLVL-Rim	JJLVL-Beam
30	270	-
39	-	234
45	-	270
75	-	450

Table 13. JJLVL-Beam and JJLVL-Rim vertical load characteristic capacities

Notes for Table 13:

1. Values for point load can be calculated as $P=UDL \times (L_b+60)/1000$ where L_b is the contact length of the load applied in mm
2. The beam is considered fully restraint, effects of buckling have been ignored
3. Factor $K_{c,90}$ has been taken as 1, however, allowance may be made for load spreading of sole plates and bottom rails at the designers discretion

JJLVL-Beam and JJLVL-Rim point loads (P) and Uniformly Distributed Load (UDL)

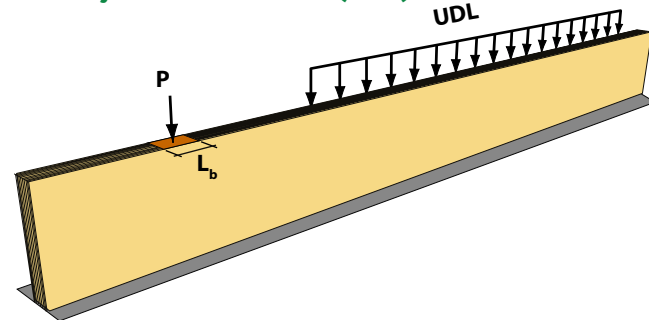

Storage on site

Glulam and LVL will typically arrive on site with a moisture content between 10% and 15%, and will achieve a moisture content of approximately 12% when installed in Service Class 1 conditions.

Glulam and LVL should be stored clear of the ground on a flat level surface and protected from the weather.

Once installed, if the structure will not be weather tight for a prolonged period of time, the Glulam and LVL should be protected from the weather to avoid excessive changes in moisture content, and associated dimensional changes.



Service holes in Glulam and LVL

Holes or notches should be formed in accordance with the guidelines given for solid timber members in The Building Regulations Approved Document "Timber Intermediate Floors for Dwellings", clause 2.5. The hole and notch diagram is applicable to uniformly loaded single span beams only. For all other applications, consult the JJI-Joist Distributor.

Service hole diagram

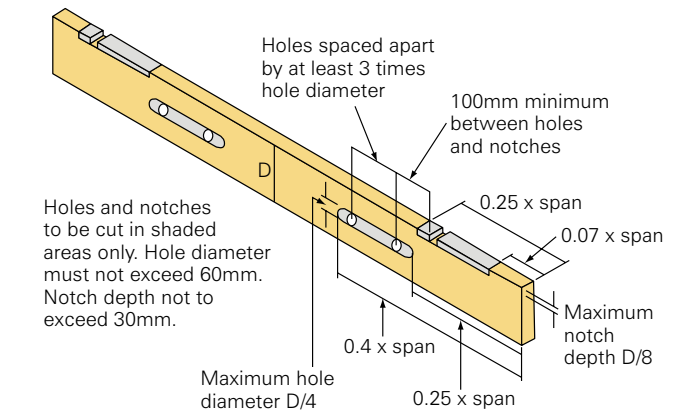

In addition to the rules given above a 35mm circular hole can be drilled at any location along the centre line of a Glulam and JJLVL member provided the following rules are observed:

1. The hole must be a minimum of one member depth away from the end of the joist
2. The hole must be a minimum of one member depth away from the nearest support
3. No two adjacent holes should be located any closer together than 70mm edge to edge
4. For holes larger than 35mm contact your Distributor for advice

Larger holes and complex loading

PD 6693-1:2012 provides a calculation method for larger holes up to 0.4 x depth of the joist. This method can be use for multi span beams and complex loading conditions.

Treatment and durability

Our Glulam and LVL products are untreated. When used in a Service Class 1 or 2 environment they will have a natural durability comparable to that of solid European white wood.

Check for compatibility before applying any preservative coating/treatment.

Fire resistance

For the purpose of calculating the fire resistance of Glulam and LVL members, detailed guidance on charring rate calculation procedures can be found in EN 1995-1-2.

Fixing of multiply Glulam and JLVVL-Beam members

Multiply Glulam and JLVVL members can be fixed together using nails, screws or bolts depending on availability and preference.

Screws - Where possible, James Jones and Sons recommend the use of large diameter self tapping screws in preference to nails or bolts. For details of the available screw sizes and advice on how they should be used please refer to the relevant metalwork manufacturer's technical literature (see page 5 for contact details).

For cases where large diameter self-tapping screws are not available, this section provides some standard nailing and bolting details.

Nails - For two ply 38/39mm and 45mm members nails are the most cost effective and easily made fixing. Nails can also be used in three ply 38/39mm and 45mm members although designers are encouraged to use a screwed connection solution where possible.

Bolts - Bolts can be used to connect together up to 5 ply 38/39/45mm and 3 ply 75mm members.

Uniformly loaded

Multiply members loaded from one face only e.g. trimmer joist with incoming joists supported in hangers at regular intervals. Tables 14a and 14b give the maximum Characteristic regular line loads that can be carried based on the connection reference (fixing detail).

Connection Ref	Section Makeup - GL28c Ply Thickness (mm)	2 ply		3 ply		4 ply		5 ply	
		38	45	38	45	38	45	38	45
	Overall width (mm)	76	90	114	135	152	180	190	225
A	2 rows of 3.1mm nails (300 centres)	11.04	11.84	8.28	8.88	-	-	-	-
B	3 rows of 3.1mm nails (300 centres)	16.56	17.75	12.42	13.32	-	-	-	-
C	2 rows of M12 bolts (600 centres)	28.95	34.29	21.71	25.71	19.30	22.86	18.09	21.43
D	2 rows of M12 bolts (400 centres)	43.43	51.43	32.57	38.57	28.95	34.29	27.14	32.14
E	2 rows of M12 bolts (300 centres)	57.90	68.57	43.43	51.43	38.60	45.71	36.19	42.86

Table 14a. Characteristic regular line loads for multiply GL28c Glulam members loaded from one face in kN/m

Connection Ref	Section Makeup - JLVVL Ply Thickness (mm)	2 ply		3 ply		4 ply		5 ply	
		45	75	45	75	45	75	45	75
	Overall width (mm)	90	150	135	225	180	225	180	225
A	2 rows of 3.1 nails (300 centres)	13.58	-	10.18	-	-	-	-	-
B	3 rows of 3.1 nails (300 centres)	20.36	-	15.27	-	-	-	-	-
C	2 rows of M12 bolts (600 centres)	43.62	62.92	37.89	47.19	33.68	31.57		
D	2 rows of M12 bolts (400 centres)	65.43	94.38	56.83	70.78	50.52	47.36		
E	2 rows of M12 bolts (300 centres)	87.25	125.84	75.78	94.38	67.36	63.15		

Table 14b. Characteristic regular line loads for multiply JLVVL-Beam members loaded from one face in kN/m

Notes for Table 14a and b:

- The values in the tables above are applicable to members loaded to one face
- Capacities for nail details are based on 3.1mm diameter power driven nails (75mm long for 38/39mm thick plies and 90mm long for 45mm plies), hammer driven nails up to 4.5mm diameter may be used
- 38mm diameter x 3mm thick washers are required under each head and nut on M12 bolts. Bolts to be minimum 4.6 grade
- Sections over 180mm wide should be loaded equally from both sides unless checked by an Engineer
- Bolt length to be no less than the overall width of beam + 18mm, e.g. a 2 ply 45mm member would require a 108mm bolt

Connection Detail A - 3 ply Beam - 2 rows of 3.1mm nails @300mm centres

CD-A-3ply

Notes

- Capacities for nail details are based on 3.1mm diameter power driven nails (75mm long for 38/39mm thick plies and 90mm long for 45mm plies), hammer driven nails up to 4.5mm diameter may be used

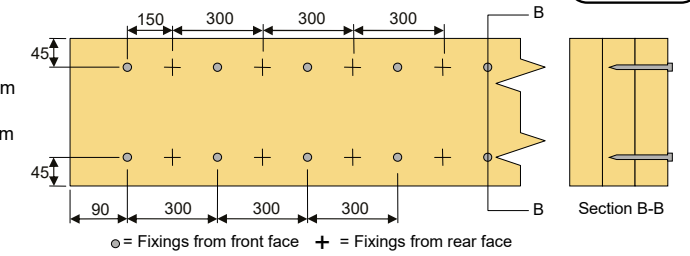

Nails in three ply members to be fixed in two rows 45mm in from the top and bottom edge, driven through each outer ply into the central ply. Nails from any one face to be 300mm centres with nails from the opposite face offset by 150mm. The minimum end distance should be 90mm.

Connection Detail B - 2 ply Beam - 3 rows of 3.1mm nails @300 centres

CD-B-2ply

Notes

- Capacities for nail details are based on 3.1mm diameter power driven nails (75mm long for 38/39mm thick plies and 90mm long for 45mm plies), hammer driven nails up to 4.5mm diameter may be used

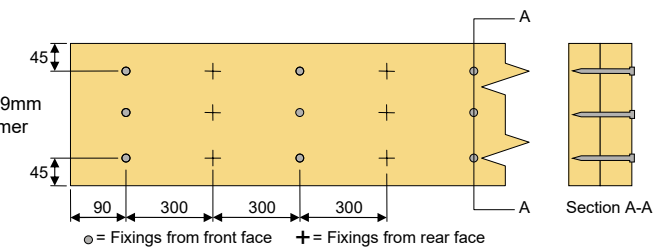

Nails in two ply members should be fixed in two rows 45mm in from the top and bottom edge and one row along the centre line, driven from alternate sides. The minimum end distance should be 90mm.

Connection Detail B - 3ply Beam - 3 rows of 3.1mm nails @300mm centres

CD-B-3ply

Notes

- Capacities for nail details are based on 3.1mm diameter power driven nails (75mm long for 38/39mm thick plies and 90mm long for 45mm plies), hammer driven nails up to 4.5mm diameter may be used

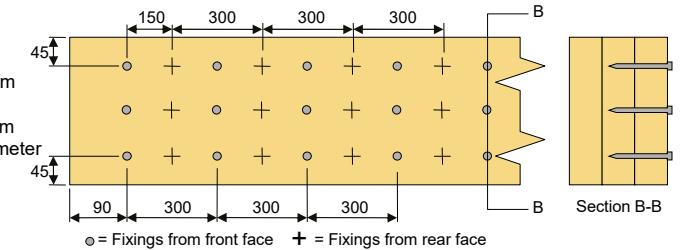

Nails in three ply members to be fixed with the outer rows 45mm in from the top and bottom edge, all nails driven through each outer ply into the central ply. Nails from any one face to be at 300mm centres with nails from the opposite face offset by 150mm. The minimum end distance should be 90mm.

Connection Detail C - Multiply Beam - 2 rows of M12 bolts @600 centres

CD-C

Notes

- 38mm diameter x 3mm thick washers are required under each head and nut on M12 bolts. Bolts to be minimum 4.6 grade
- Bolt length to be no less than the overall width of beam + 18mm, e.g. a 90mm beam and rim would require a 108mm bolt

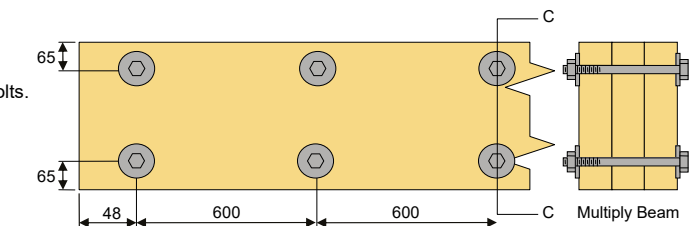

Bolts should be fixed in two rows 65mm in from the top and bottom edge, Bolts should be drilled at Ø12mm and bolts tapped into place. The minimum end distance should be 48mm.

Connection Detail A - 2 ply Beam - 2 rows of 3.1mm nails @300mm centres

CD-A-2ply

Notes

- Capacities for nail details are based on 3.1mm diameter power driven nails (75mm long for 38/39mm thick plies and 90mm long for 45mm plies), hammer driven nails up to 4.5mm diameter may be used

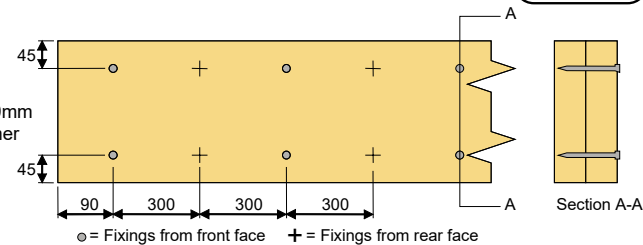

Nails in two ply members to be fixed in two rows 45mm in from the top and bottom edge, driven from alternate sides. The minimum end distance should be 90mm.

Connection Detail D - Multiply Beam - 2 rows of M12 bolts @400 centres **CD-D**

Notes

- 38mm diameter x 3mm thick washers are required under each head and nut on M12 bolts. Bolts to be minimum 4.6 grade
- Bolt length to be no less than the overall width of beam + 18mm, e.g. a 90mm beam and rim would require a 108mm bolt

Bolts should be fixed in two rows 65mm in from the top and bottom edge, Bolts should be drilled at Ø12mm and bolts tapped into place. The minimum end distance should be 48mm.

Connection Detail E - Multiply Beam - 2 rows of M12 bolts @300mm centres **CD-E**

Notes

- 38mm diameter x 3mm thick washers are required under each head and nut on M12 bolts. Bolts to be minimum 4.6 grade
- Bolt length to be no less than the overall width of beam + 18mm, e.g. a 90mm beam would require a 108mm bolt

Bolts should be fixed in two rows 65mm in from the top and bottom edge, bolts should be drilled at Ø12mm and bolts tapped into place. The minimum end distance should be 48mm.

Isolated Point Loads

Multiply members with localised fixings close to an incoming member e.g. trimming joist supporting a specific trimmer joist. Tables 15a and 15b give the maximum Characteristic isolated load that can be carried based on the connection reference (fixing detail).

Connection Ref	Section Makeup Ply Thickness (mm)	2 ply			3 ply		4 ply	
		38	45	90	38	45	38	45
	Overall width (mm)	76	90	180	114	135	152	180
F	Nail Detail	19.87	21.30	-	14.90	15.98	-	-
G	Bolt Detail	34.74	41.14	66.94	26.06	30.86	23.16	27.43

Table 15a. Characteristic isolated point loads for multiply GL28c Glulam members in kN

Connection Ref	Section Makeup Ply Thickness (mm)	2ply		3ply		4ply
		45	75	45	75	45
	Overall width (mm)	90	150	135	225	180
F	Nail Detail	24.44	-	18.33	-	-
G	Bolt Detail	52.35	75.50	45.47	56.63	40.41

Table 15b. Characteristic isolated point loads for multiply JLV-BEAM members in kN

Notes for Table 15a and b:

- The values in the tables above are applicable to members loaded to one face only in floor applications
- Capacities for nail details are based on 3.1mm diameter power driven nails (75mm long for 38mm thick plies and 90mm long for 45mm plies), hammer driven nails up to 4.5mm diameter may be used
- 38mm diameter x 3mm thick washers are required under each head and nut on M12 bolts. Bolts to be minimum 4.6 grade
- Bolt length to be no less than the overall width of beam + 18mm, e.g. a 2 ply 45mm member would require a 108mm bolt

Connection Detail F - 2 ply Beam - 3 rows of 3.1 mm nails @90mm spacing **CD-F-2ply**

Notes

- Capacities for nail details are based on 3.1mm diameter power driven nails (75mm long for 38mm thick plies and 90mm long for 45mm plies), hammer driven nails up to 4.5mm diameter may be used

○ = Fixings from front face/hanger location

Connection Detail F - 3ply Beam - 3 rows of 3.1mm nails @90mm spacing **CD-F-3ply**

Notes

- Capacities for nail details are based on 3.1mm diameter power driven nails (75mm long for 38/39mm thick plies and 90mm long for 45mm plies), hammer driven nails up to 4.5mm diameter may be used

○ = Fixings from front face + = Fixings from rear face

Nails in three ply members to be fixed with the outer rows 45mm in from the top and bottom edge, all nails driven through each outer ply into the central ply.
Nails from any one face to be at 180mm centres with nails from the opposite face offset by 90mm.

Connection Detail G - Multiply Beam - 2 rows of M12 bolts @90mm spacing **CD-G**

Notes

- 38mm diameter x 3mm thick washers are required under each head and nut on M12 bolts. Bolts to be minimum 4.6 grade
- Bolt length to be no less than the overall width of beam + 18mm, e.g. a 90mm beam would require a 108mm bolt

Bolts should be fixed in two rows 65mm in from the top and bottom edge, bolts should be drilled at Ø12mm and bolts tapped into place.

SECTION 4

FLOOR DESIGN



The Park-Forres

Since the introduction of the JJI-Joist into the UK in 1999, I-Joists have become the floor system of choice for the majority of the major house builders and JJI-Joists are the market leader. The JJI-Joist system ensures that the optimum combination of performance and price is achieved first time, every time.

FLOOR DESIGN

Factors affecting floor performance

The following list describes factors that affect floor performance and consideration of these factors may be helpful when designing and installing a JJI-Joist floor system:



Joist depth

Deeper joists create a stiffer floor thereby reducing deflection. A deep floor joist solution may in fact be cheaper than a shallow joist solution as you may be able to use thinner joists at wider centres.

Deck fixing

A correctly nailed/screwed floor deck will improve floor performance by about 12%*. Gluing the floor deck to the joists, and gluing tongued and grooved joints is required by NHBC Standards Section 6.4.19. In addition, the floor performance can improve by as much as 70% when the floor deck is glued to the joists*. Refer to deck manufacturing guidelines.

Deck thickness

Thicker floor deck material will improve the floor performance.

Ceiling treatments

Directly applied ceiling finishes will improve floor performance by about 3%*.

Blocking

Full depth blocking will improve floor performance.

Workmanship

Good quality workmanship is essential to achieve good floor performance. The provision of well prepared and level bearings, methodical erection procedure, diligent installation of all fixings and in particular fixing of the floor deck (including gluing where required) will have a significant effect on floor performance. The maximum acceptable tolerance on the level of bearings is +/- 3mm.

* Figures obtained from independent laboratory tests originating from a government (DETR) research project.

Special consideration for ground floor design

Timber in ground floor construction is in a more moist environment than timber in an upper floor. As such, JJI-Joists for use in ground floors should be designed using joist properties for Service Class 2 conditions.



Insulation

Thermal insulation is required in all ground floors and each different building type should be assessed individually to identify the specific U-value requirements and thus the corresponding thickness of insulation to be used. Three options for providing ground floor insulation are as follows:

- Quilt insulation supported on plastic netting or breather membrane
- Quilt insulation supported on a board fixed to the top side of the bottom flange of the JJI-Joist
- Solid insulation supported on bottom flange of the JJI-Joist

Most heat loss through a ground floor occurs around the floor perimeter and so the inclusion at the edges helps maintain overall insulation levels.

Resistance to moisture

All suspended ground floors should be constructed to resist the ingress of moisture. Where external ground level is above the ground cover level, then the ground cover should be laid to fall to a suitable drainage outlet.

Ventilation

All parts of the void underneath the suspended floor require a ventilation path to the outside. For guidance on ventilation requirements, refer to the applicable building regulations.

Radon gas

The construction of suspended timber ground floors in areas affected by Radon gas requires specialist advice.

DOMESTIC FLOOR SPAN TABLES

Domestic floor span tables

The domestic intermediate floor span table below is based on the following design criteria:

- Dead Load including partition allowance is 1.35kN/m² for apartments or 0.75kN/m² for houses
- The spans given are for simply supported and uniformly loaded joists only
- Where the load conditions are different to those described, refer to the JJI-Joist supplier for further assistance

- The joists are designed using the principles of EN1995-1-1 (Eurocode 5)
 - Adequate lateral restraint to the top flange of the joists is assumed to be provided by the floor deck
- Further details are provided in the notes below the table.

Joist Type	Apartments			Houses		
	Dead Load up to 1.35kN/m ²			Dead Load up to 0.75kN/m ²		
	Joists Centres (mm)			Joists Centres (mm)		
	400	480	600	400	480	600
JJI 195A+	3621	3372	3086	4024	3768	3459
JJI 220A+	4012	3740	3427	4318	4152	3834
JJI 220B+	4493	4183	3826	4724	4542	4292
JJI 220C	4669	4345	3970	4871	4683	4459
JJI 220D	5182	4815	4391	5297	5093	4890
JJI 235A+	4228	3944	3615	4477	4305	4042
JJI 235B+	4728	4405	4031	4890	4702	4514
JJI 235C	4919	4580	4188	5046	4852	4658
JJI 235D	5462	5078	4635	5488	5277	5066
JJI 240A+	4299	4010	3677	4528	4354	4109
JJI 240B+	4801	4474	4095	4941	4751	4561
JJI 240C	5000	4656	4259	5102	4906	4711
JJI 240D	5551	5167	4717	5551	5338	5125
JJI 245A+	4368	4076	3737	4579	4403	4176
JJI 245B+	4873	4541	4157	4991	4799	4607
JJI 245C	5081	4732	4330	5158	4960	4762
JJI 245D	5615	5255	4798	5615	5399	5184
JJI 300A+	5116	4783	4393	5116	4919	4723
JJI 300B+	5529	5278	4841	5529	5316	5104
JJI 300C	5752	5531	5085	5752	5531	5310
JJI 300D	6286	6044	5673	6286	6044	5803
JJI 350A+	5519	5307	4905	5519	5307	5095
JJI 350B+	5920	5692	5360	5920	5692	5465
JJI 350C	6287	6045	5780	6287	6045	5804
JJI 350D	6817	6555	6293	6817	6555	6293
JJI 400D	7260	6981	6703	7260	6981	6703

Table 16. Maximum Engineering Span for Domestic Intermediate Floors

Notes for Table 16:

1. This table serves as guidance only. For a more detailed JJI-Joist appraisal contact a JJI-Joist Distributor. The calculated spans are engineering spans in mm
2. This table has been calculated for domestic intermediate floors (Service Class 1)
3. Load combinations equations 6.10aSTR 6.10bSTR (EN1990) have been used in this table
4. The effect of partition load has been included where the self-weight of the floor does not exceed 1.0kN/m² for apartments or 0.4kN/m² for houses
5. The calculated spans are engineering spans for simply supported joists with a medium term imposed load (q_k=1.5kN/m², Q_k=2.0kN)

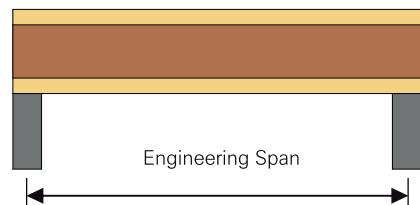

6. Adequate lateral restraint is provided by the floor deck (22mm chipboard and 15mm plasterboard)
7. It is assumed that load can be shared between floor joists (K_{sys}=1.1)
8. Joists design values have been calculated using K_{mod} factors from table 3.1 (EN1995) and γ_{M,timber}=1.3, γ_{M,OSB}=1.2
9. Final deflection limit has been taken as L/250. No additional instantaneous deflection limit has been applied
10. The unit load deflection limit is 1.8mm for spans below 4000 and 16500/L^{1.1} for spans over 4m
11. Fundamental frequency has been limited to 8Hz
12. The modal dampening ratio is 0.02
13. The floor width has been taken as 4m for velocity response checks
14. To achieve stated span, adequate bearing will be required. Web stiffeners may be necessary
15. Permissible web holes to be drilled in accordance to Joistmaster software or hole chart
16. Standard JJI-Joist products shown within table. For non-standard JJI-Joist products (see Table 1) refer to approved Distributor for availability

F-DETAILS

Example of JJI-Joist floor system

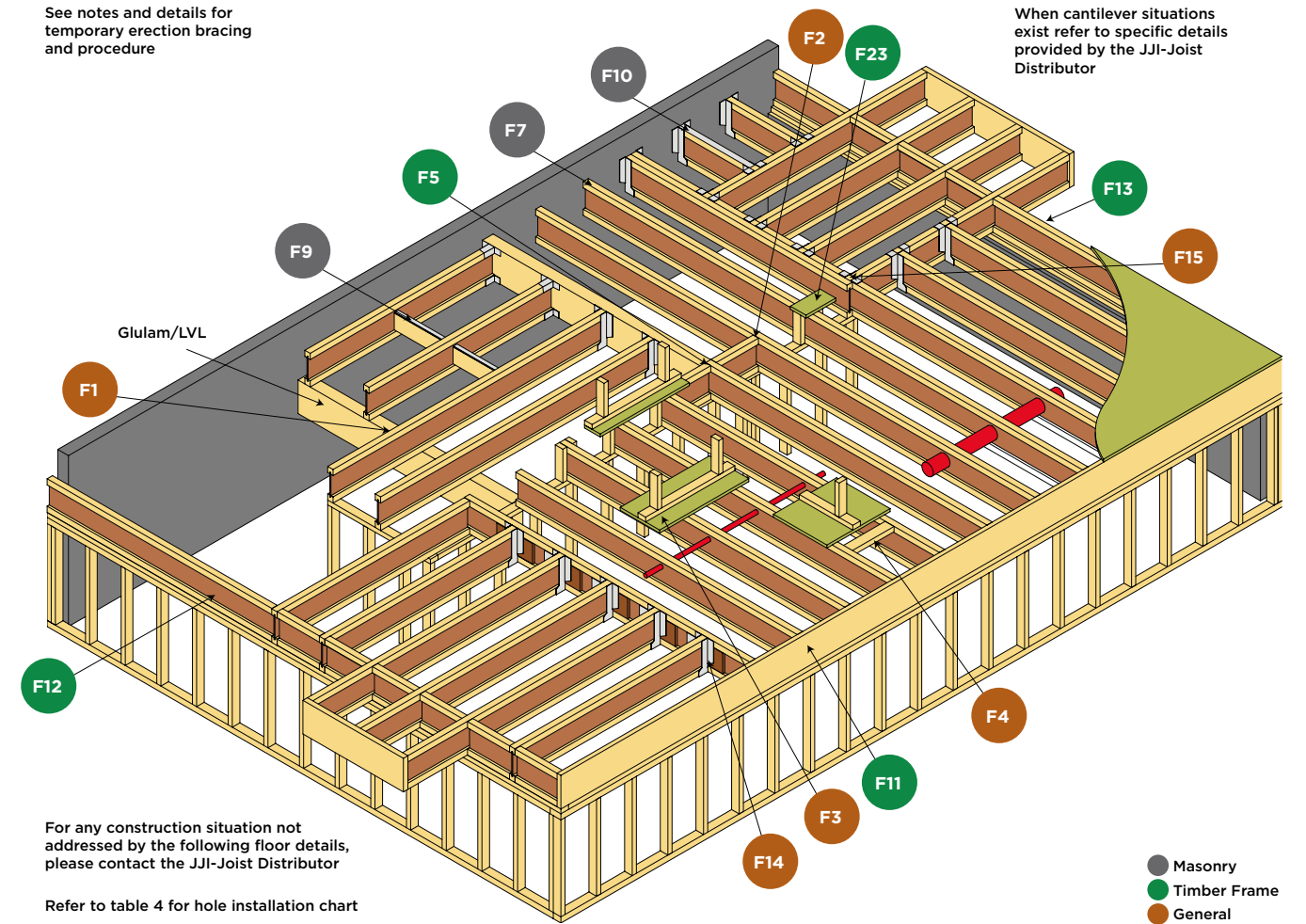

F1 - CONTINUOUS JOIST ON WALL

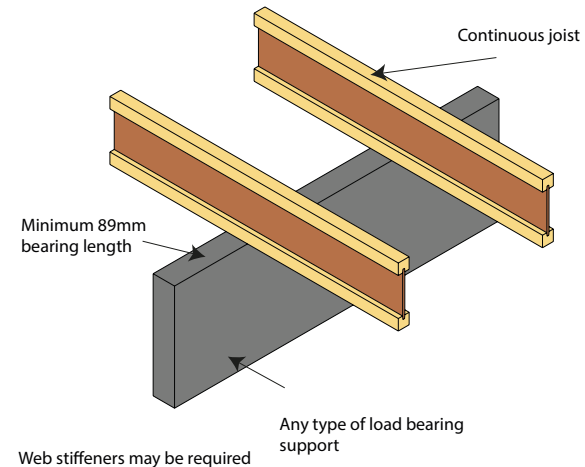

F2 - SPLIT JOIST ON WALL

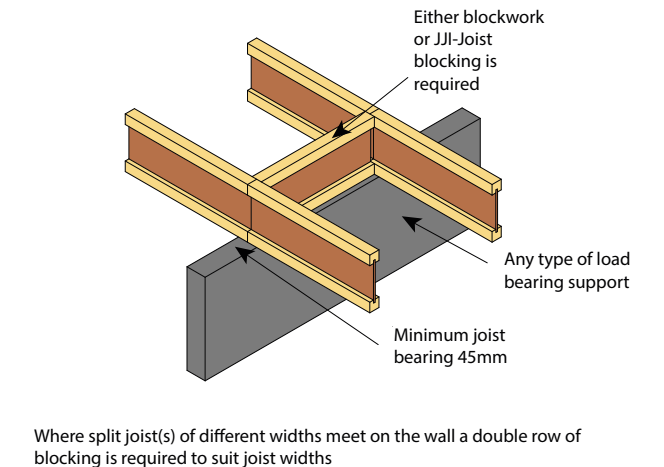

F3 - WALL AT 90° TO JOISTS

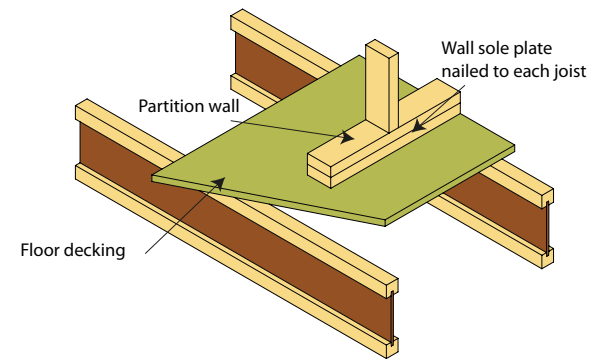

The floor designer is responsible for ensuring the joist design is adequate to support the wall

F4 - NON LOAD BEARING WALL PARALLEL TO JOISTS

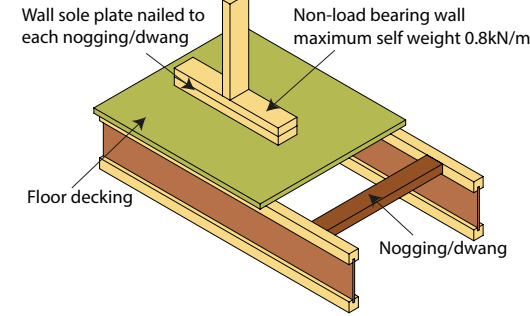

Minimum 38 x 72mm nogging/dwang or JJI-C flange at maximum 600 c/c attached with 2 no. 3.35 x 65mm nails skew nailed at each end, alternatively use approved clips
The floor designer is responsible for ensuring the joist design is adequate to support the wall

F5 - INTERMEDIATE BEARING WITH LOAD BEARING WALL ABOVE

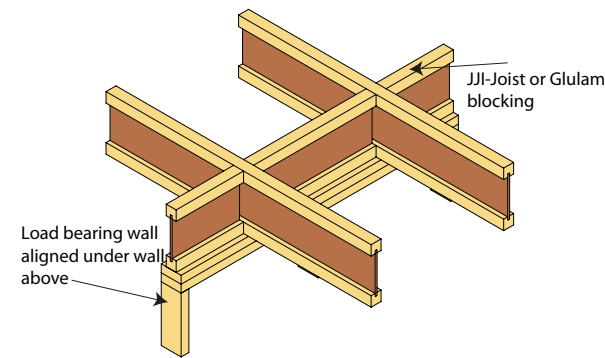

F6 - TERMINATING JOIST ON WALL

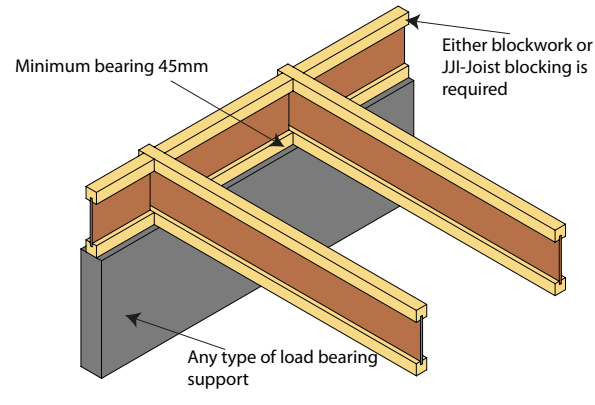

Suitable detailing required if used on an external wall

F7 - TERMINATING JOIST ON WALL

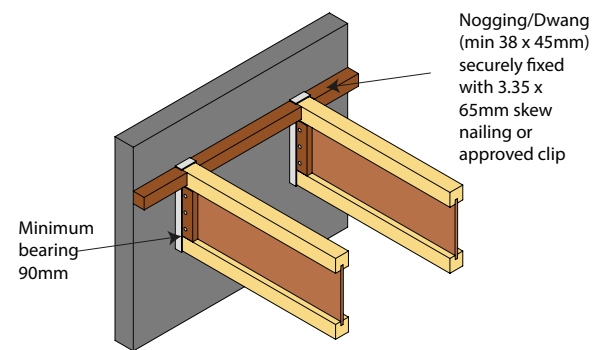

Construct blockwork around joist and fill all voids with web fillers, mortar and point with mastic sealant
Alternative proprietary systems may be used if approved by JJ&S
Restraint straps will be required for greater than 2 storey*
*Straps required on all floors

F8 - MASONRY WALL RESTRAINT JJI-JOIST PARALLEL DETAIL 1

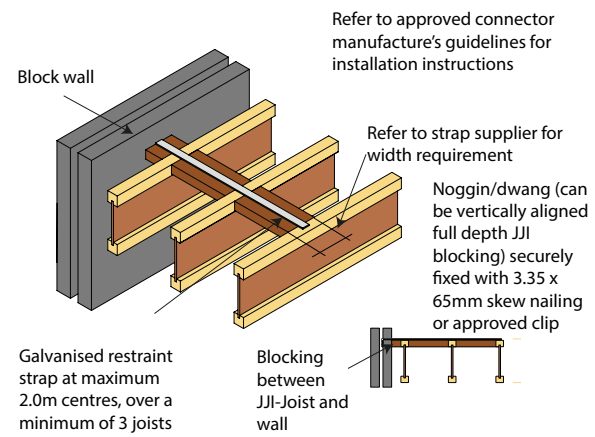

F9 - MASONRY WALL RESTRAINT JJI-JOIST PARALLEL DETAIL 2

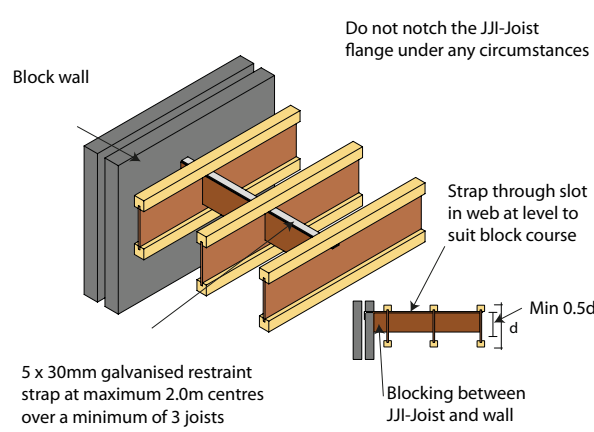

F11 - JJI-JOIST BEARING ON EXTERNAL WALL

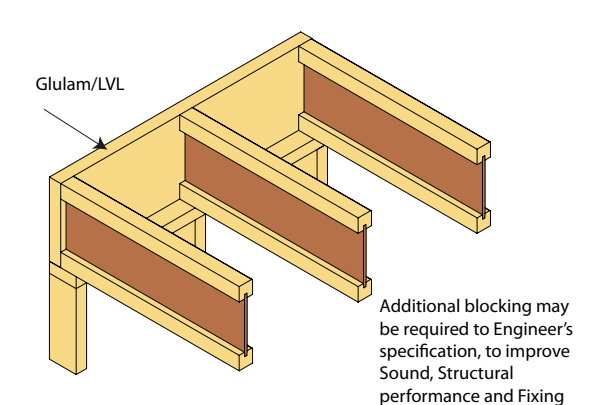

F10 - WALL RESTRAINT, BLOCK WALL HANGER SUPPORT

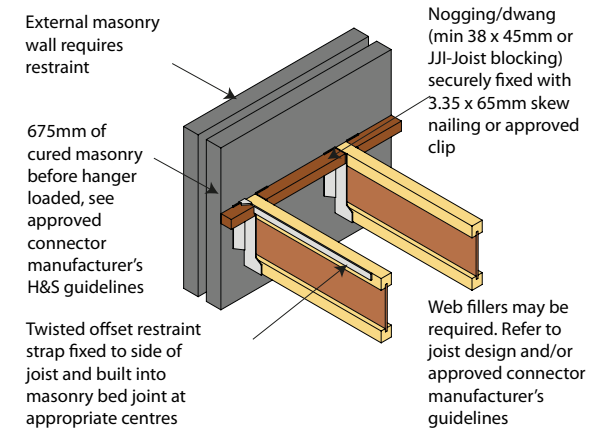

F14 - SINGLE JJI-JOIST TO JJI-JOIST

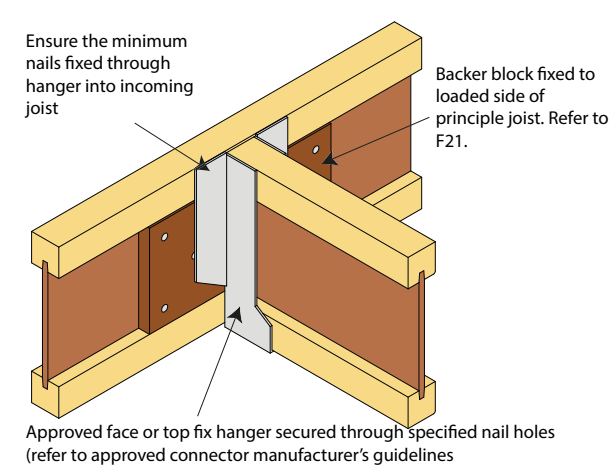

F15 - SINGLE JJI-JOIST TO MULTIPLE JJI-JOIST

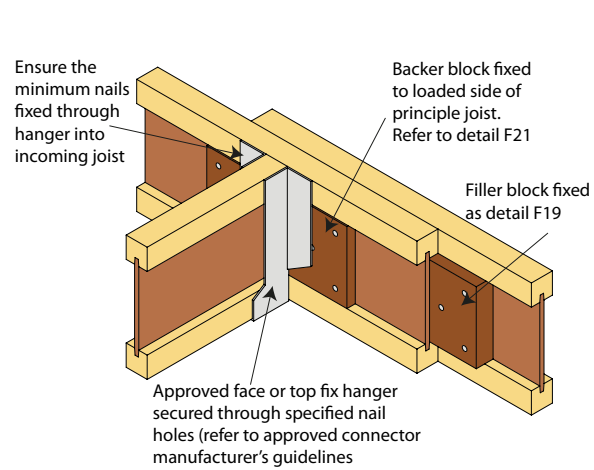

F16 - SINGLE JJI-JOIST TO JJI-JOIST (LIGHT LOAD)

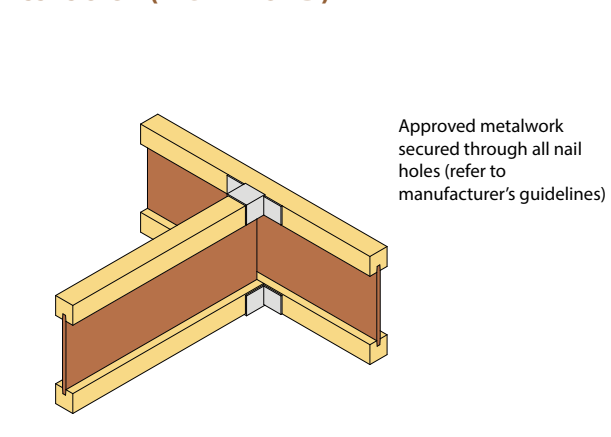

F17 - MULTIPLE JJI-JOIST TO JJI-JOIST

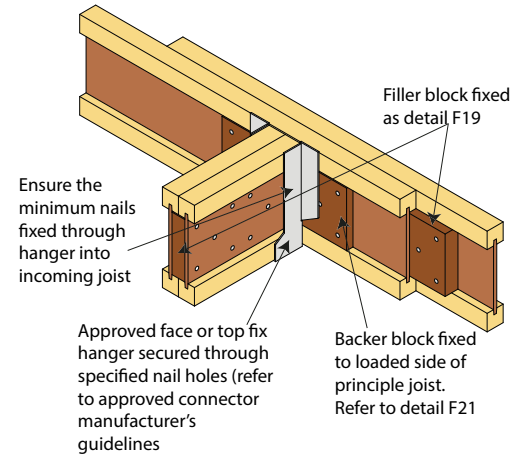

F18 - JJI-JOIST TO ENGINEERED TIMBER

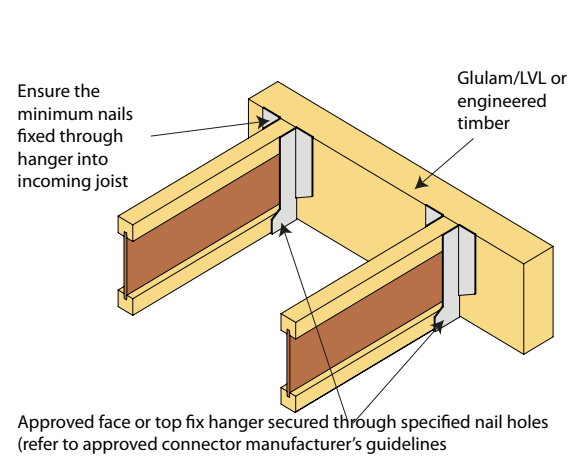

F23 - COMPRESSION BLOCK

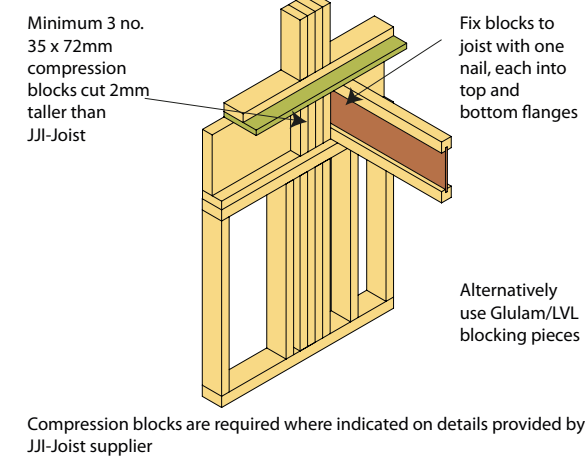

F24 - CANTILEVER

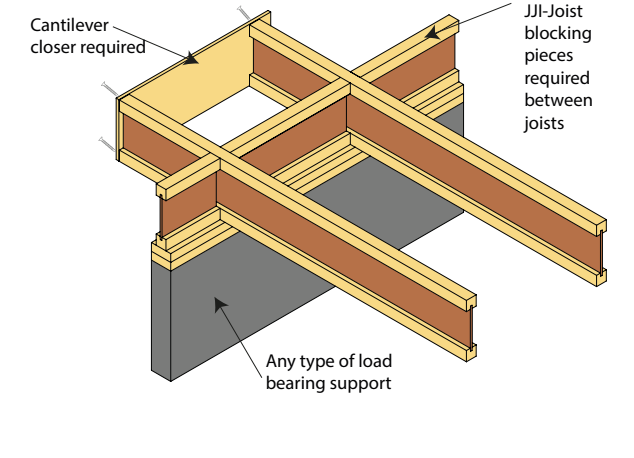

F19 - FILLER BLOCK-DOUBLE OR TREBLE JJI-JOIST

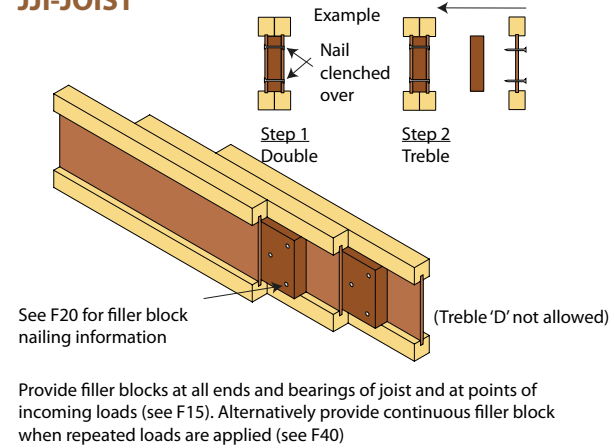

F20 - FILLER AND BACKER BLOCK TABLE

JJI-Joist Depth (mm)	Filler and backer block depth (mm)	JJI-Joist Flange Type	Backer block/web stiffener thickness (mm)	Filler block thickness (mm)
195	100	A+	19	38
220	125	B+	27	54
235/240	145	C	32	63
245	150	D	44	2x44
300	200	Refer to details provided by the JJI-Joist supplier for required locations of filler and backer blocks		
350	125+125	Where a continuous filler block is used see detail F40		
400	150+150	Filler and backer blocks should be kiln dried timber, structural grade plywood or OSB/3		

F25 - STAIR STRINGER CONNECTION

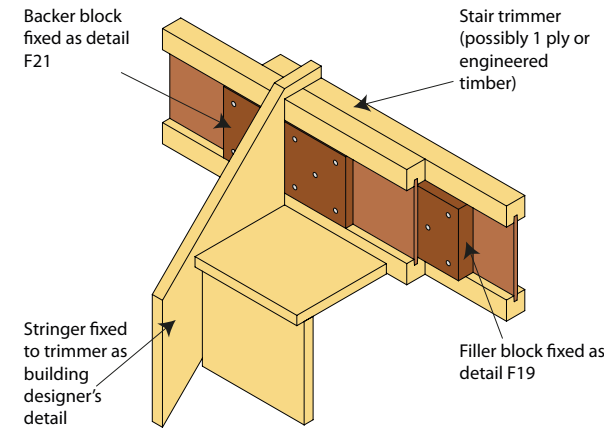

F26 - JJI-JOIST SUPPORTED ON STEEL/ CORBEL WALL

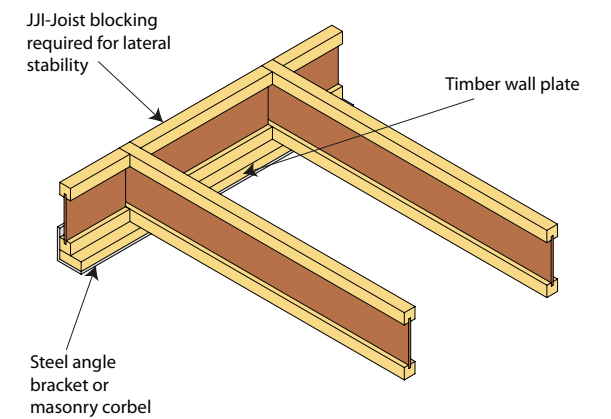

F21 - FILLER AND BACKER BLOCK NAILING DETAIL

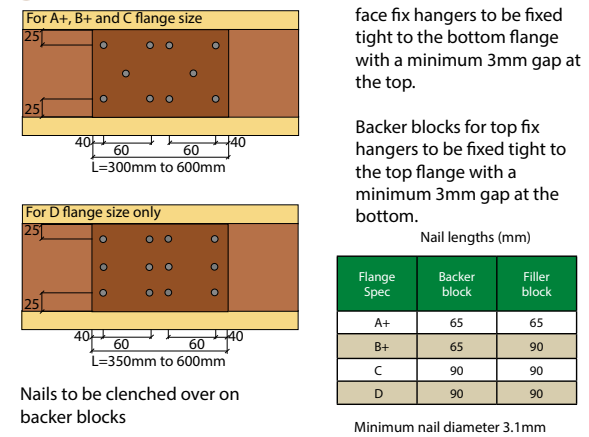

F22 - WEB STIFFENER

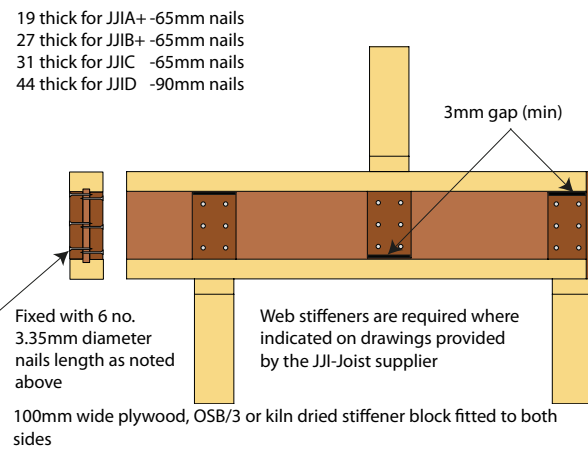

F27 - LOAD BEARING WALL PARALLEL TO JJI-JOIST RUN

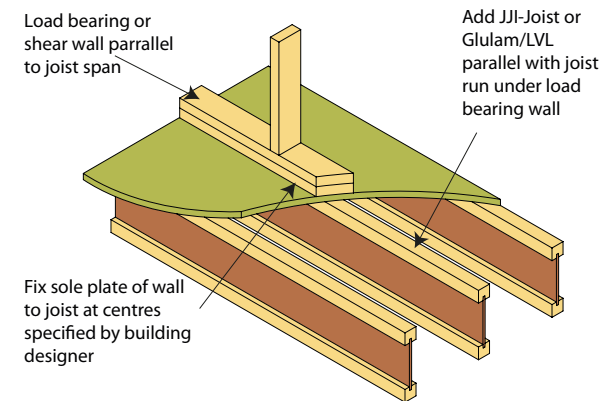

F28 - NEWEL POST TO JJI-JOIST TRIMMER

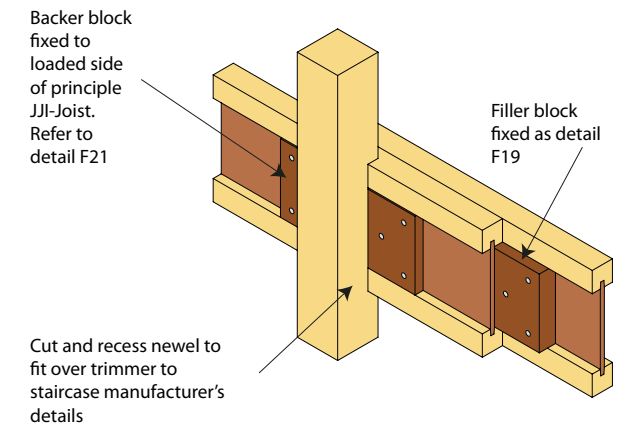

F29 - JJI-JOIST TO STEEL BEAM FACE FIXING

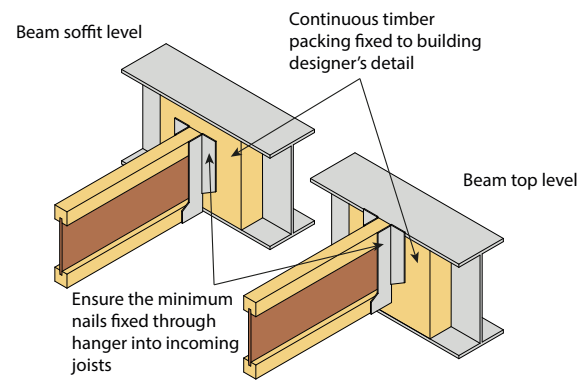

Approved face fixed hangers fixed through all nail holes
Refer to approved metal work supplier's literature for further information

F30 - JJI-JOIST TO STEEL BEAM/MASONRY

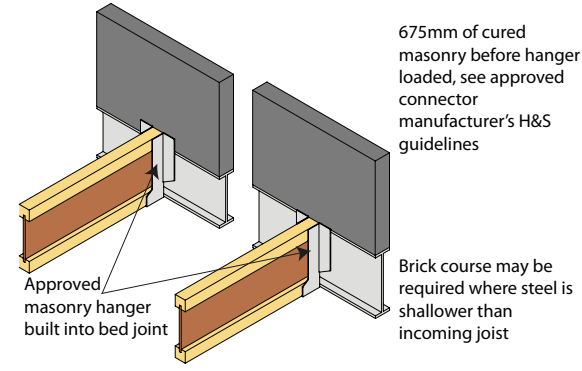

Do not fix joist to steel lintels unless approved by lintel manufacturer
Bottom of hanger must rest against bottom flange of steel beam
Refer to approved metalwork supplier's literature for further information

F31 - JJI-JOIST TO STEEL BEAM TOP FIXING

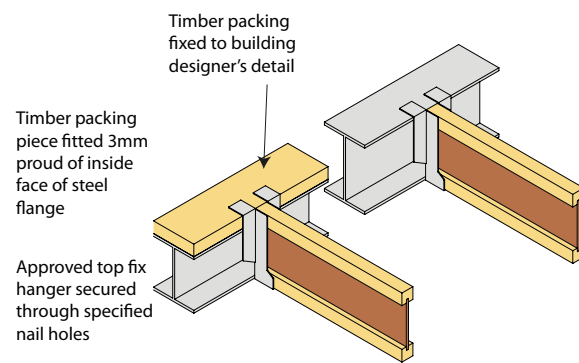

Bottom of flange must rest against bottom flange of steel beam
Do not fix joist to steel lintels unless approved by lintel manufacturer
Refer to approved metalwork supplier's literature for further information

F32 - JJI-JOIST BEARING ON PARTY WALL

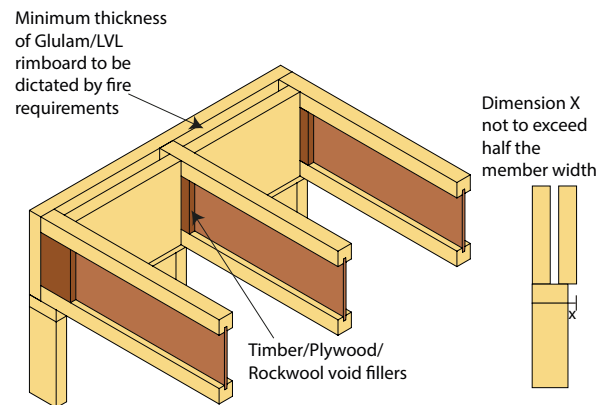

F33 - JJI-JOIST PARALLEL TO PARTY WALL

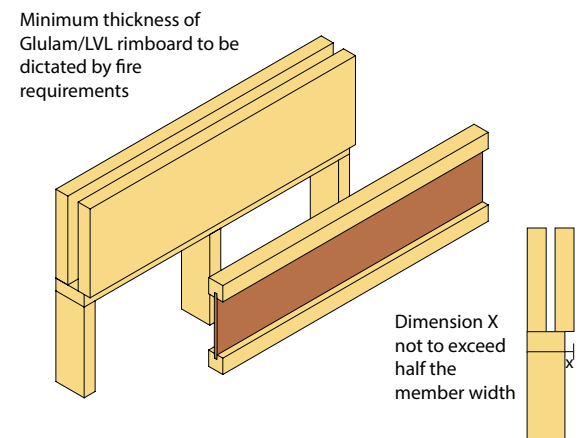

F34 - INDICATIVE DISPROPORTIONATE COLLAPSE JJI-JOISTS AT 90° TO WALL

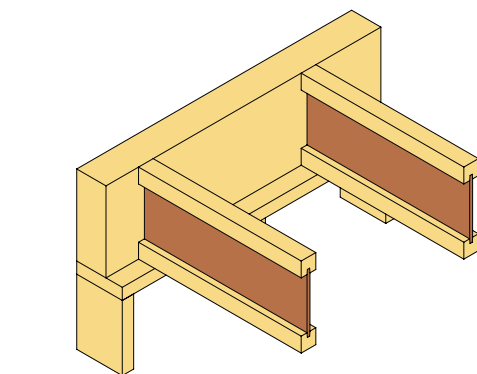

Specification to Engineer's detail

F35 - INDICATIVE DISPROPORTIONATE COLLAPSE JJI-JOISTS PARALLEL TO WALL

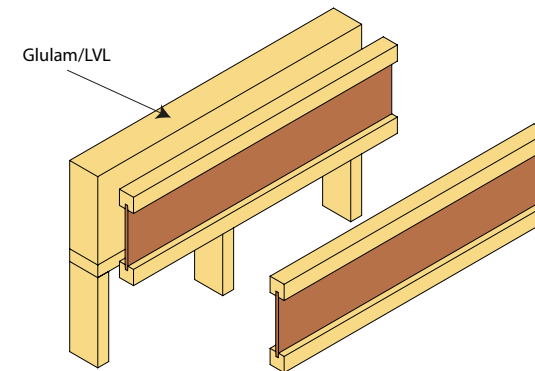

Specification to Engineer's detail

F36 - JJI-JOIST PARALLEL TO EXTERNAL WALL

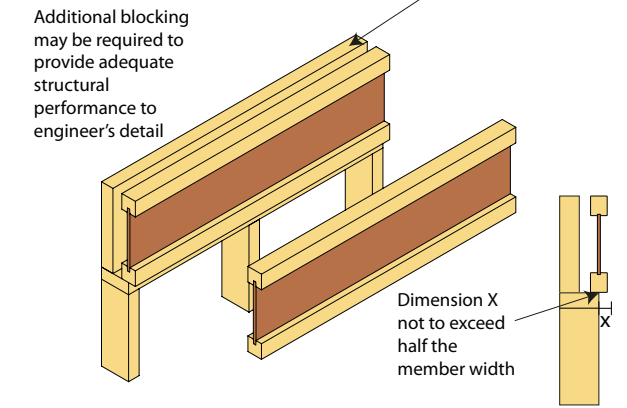

F37 - FLOOR CASSETTE JOINING DETAIL

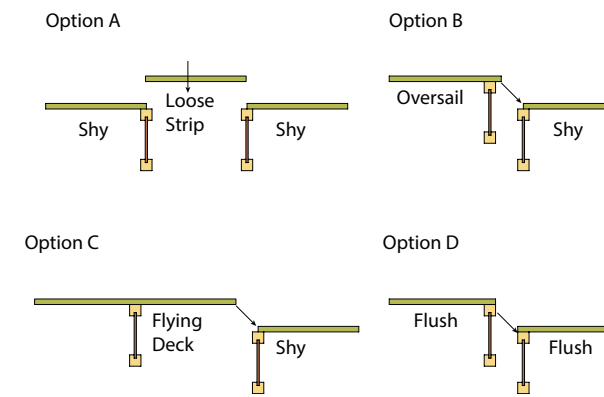

For options B & D joists should be structurally connected to prevent differential movement and maintain diaphragm action where required

Timber frame detail notes

1. See Tables 3, 8 and 13 for vertical load capacities
2. Rimboard thickness to timber frame kit manufacturer's Consulting Engineer's specification/approval
3. Rimboard fixed to bearing with 3.35 x 65mm nails at 150mm c/c
4. Secure rimboard to JJI-Joist with 2 no. 3.35 x 65mm ring shank nails, one each to top and bottom flanges
5. Fix JJI-Joist to bearing with 2 no. 3.35 x 65mm nails, 40mm from joist end
6. Minimum joist bearing length 45mm
7. Ensure the Building Designer is satisfied with fixing between the wall and floor

F39 - ENHANCED HANGER UPLIFT

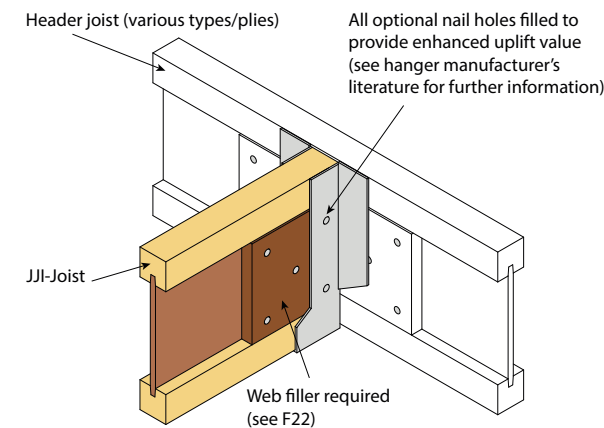

F40 - CONTINUOUS FILLER & BACKER BLOCKS

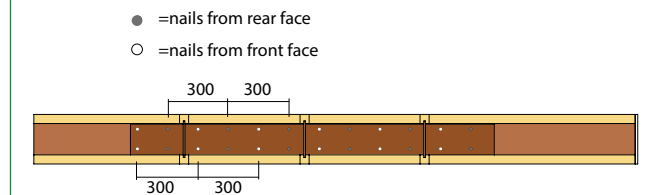

A continuous filler block should be utilised with multiple incoming loads
A continuous backer block could also be provided
Were continuous filler block is used, fix with 2 rows of nails at 300mm centres from both faces

F41 - BACKER FREE JOIST TO JOIST

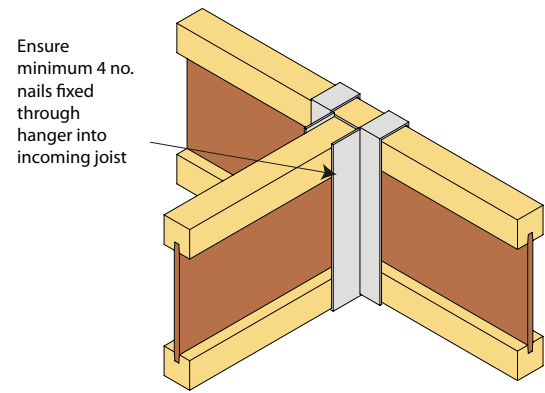

Approved backer free hanger secured through specified nail holes
Refer to approved connector manufacturer's guidelines

F42 - FIXING DOUBLE OR TREBLE JJI-JOISTS

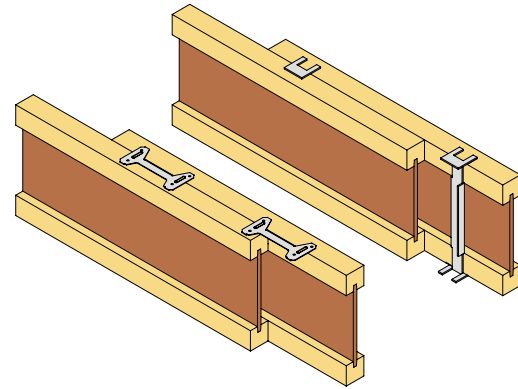

Refer to approved metalwork supplier's technical literature for specification and installation guidelines

F43 - FIXING DOUBLE JJI-JOISTS

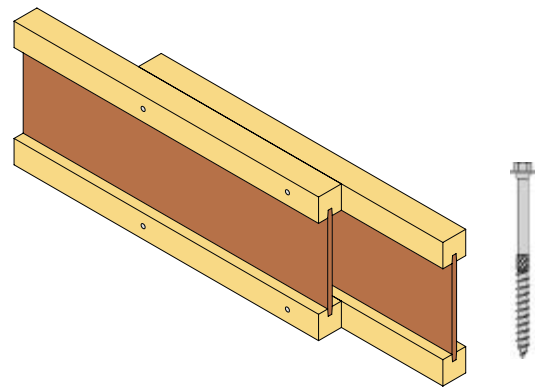

Refer to approved metalwork supplier's technical literature for specification and installation guidelines

F45 - MASONRY RESTRAINT HANGER DETAIL 1

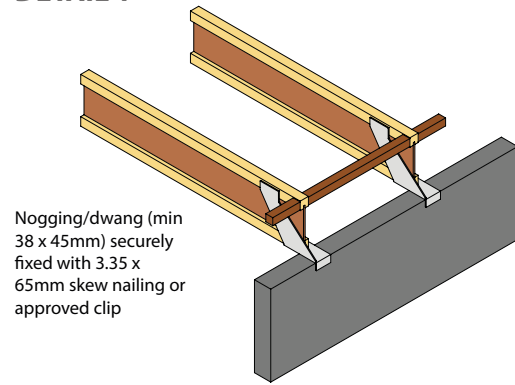

Refer to ITW's technical literature for specification and installation guidelines

F46 - MASONRY RESTRAINT HANGER DETAIL 2

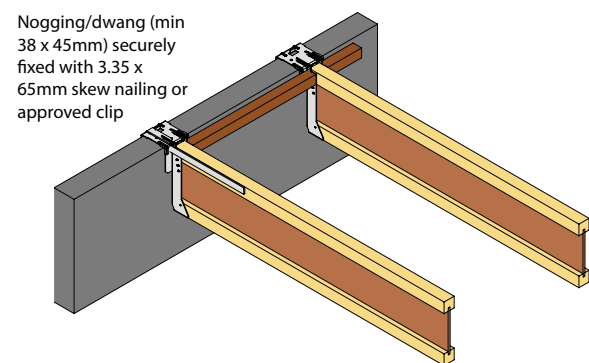

Refer to Simpson Strongtie's technical literature for specification and installation guidelines

F47 - SST END CAP AIRTIGHTNESS DETAIL 1

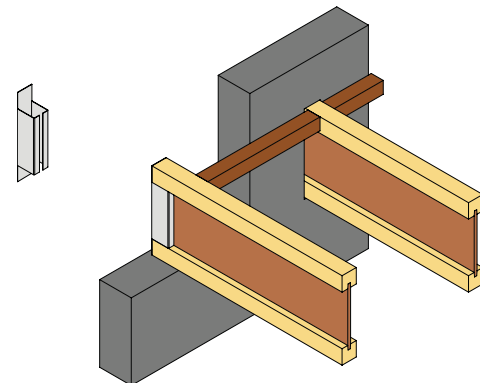

Refer to Simpson Strongtie's technical literature for specification and installation guidelines

F48 - ITW GRIPPER AIRTIGHTNESS

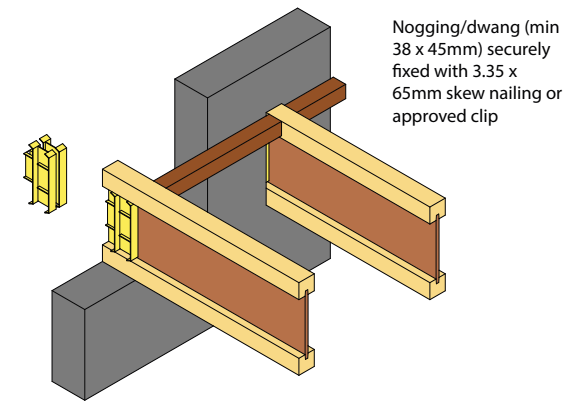

Refer to ITW's technical literature for specification and installation guidelines

F49 - JJI-JOIST BEARING ON EXTERNAL WALL LOW LOAD

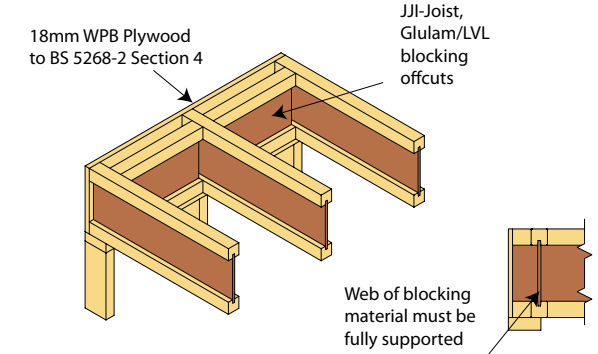

Alternatively use Glulam/LVL blocking in lieu of JJI-Joists
JJI-Joist blocking offcuts can be of any joist width

F50 - JJI-JOIST PARALLEL TO EXTERNAL WALL LOW LOAD

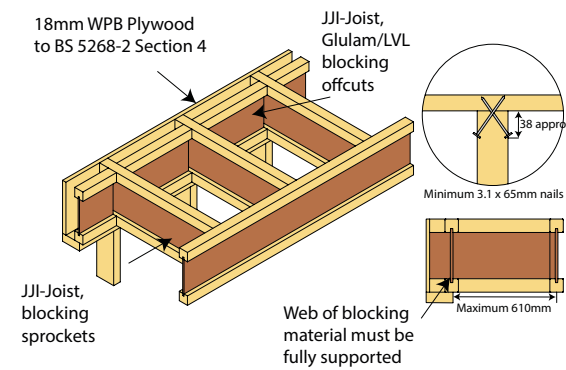

Alternatively use Glulam/LVL blocking in lieu of JJI-Joists
JJI-Joist blocking offcuts can be of any joist width

F51 - JJI-JOIST PARALLEL DETAIL - SPROCKETS

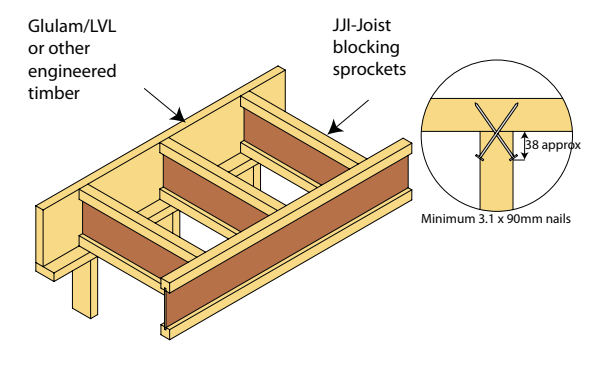

Refer to F Detail notes-timber frame

To view our full range of 3D details click or scan the QR code

SECTION 5 ROOF DESIGN



Forestry Commission-Smithton, Inverness

By making the most of their long spanning capabilities, JJI-Joists are ideally suited for use in roofs. This allows the designer the freedom to create large open room spaces without the need for additional supports.

DESIGN CONSIDERATIONS



Design considerations

Unlike a floor design, a full roof design requires many additional considerations due to its location on the exposed envelope of the building and potentially complex geometry. Unlike floors, a roof is exposed to direct wind and snow loading.

Loading

Dead loads should be calculated for each job based on the specific roof makeup. Refer to BS 648 Weights of Building Materials or manufacturers literature for material data.

Imposed snow and wind loads should be based on the location of the building if known or alternatively on conservative estimates. EN 1991-1-3 and EN 1991-1-4 should be used for snow and wind loading respectively.

Joist stability

Roofs should be braced during the erection process. Refer to temporary erection bracing notes, (See page 16).

The compression flange of the JJI-Joist requires lateral restraint at regular centres to prevent lateral buckling. This can be achieved by using a permanent structural sarking layer directly fixed to the joist or alternatively by battens/furring strips fixed perpendicular to each joist.

Where a wind load analysis indicates that the rafters will experience a stress reversal under wind suction loads, care should be taken to ensure that the bottom flange of the joist is suitably restrained. This can be achieved by, for example, directly applying a ceiling/soffit lining to the underside of the joists.

Blocking or cross-bracing (see Roof Detail R10) may be required at support locations unless joists are held in place by alternative means.



Building stability

Lateral restraint to gable walls etc. can be provided using details similar to those used for floors.

Racking of the whole roof structure should be prevented by the use of structural sarking or a system of triangulated bracing (this is required where only felt and tiling battens are used).

Deflection limits

When considering member deflection a maximum limit of $L/250$ as defined in the UK national annex to EC5 is recommended. When a finished ceiling is applied to the underside of the roof, for long spans, the designer should consider restricting the maximum deflection further to avoid damage to the finishing. The designer should also consider a more strict deflection limit for principal members such as ridge beams and purlins to minimise combined deflection.

Fixings

Fixing JJI-Joists to supports needs careful consideration to account for axial, tangential, horizontal and vertical loads. Particular care should be taken when considering uplift forces due to wind suction.



Ventilation and condensation

The full roof make-up should be assessed by the Building Designer to ensure that interstitial condensation is eliminated and care should be taken to provide appropriate ventilation to all areas of the roof required.

Responsibilities

A full roof design will address all the above issues, however, they may be dealt with by different parties (Roof Component Designer, Roof Designer, Building Designer). It is vital that the responsibility of each party is clearly defined at the start of the design process.

Example of JJI-Joist flat roof system

See notes and details for temporary erection bracing and procedure

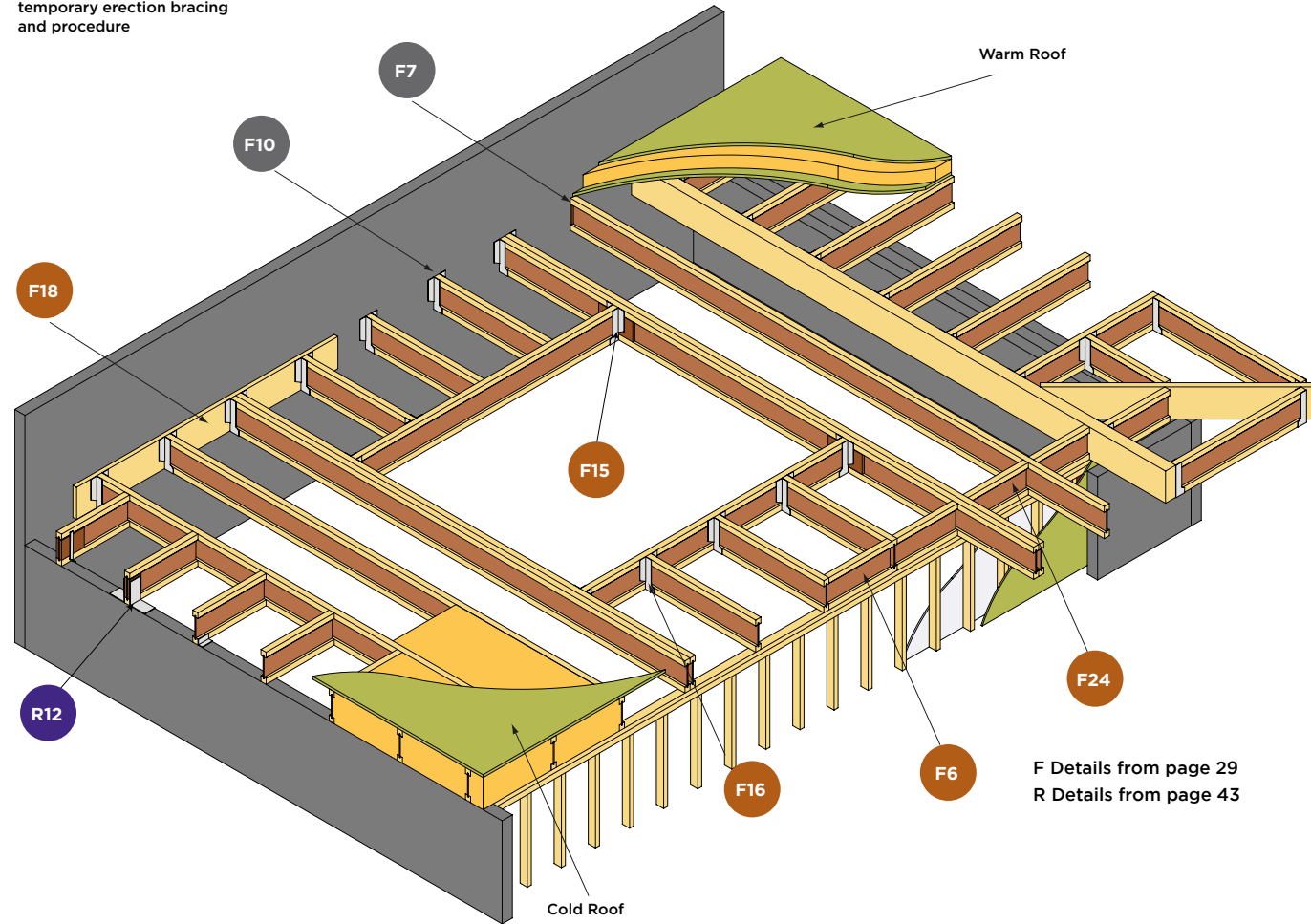

Insulation-Cold roof vs warm roof design

A traditional cold roof design positions the insulation layer between or below the JJI-Joist rafters. This places parts of the roof structure above the insulation in a cold environment, with the potential for condensation when warm air permeates through. Adequate roof space ventilation must be provided to remove this air.

A warm roof is a modern alternative to a cold roof. A warm roof design places the insulating layer above the JJI-Joist rafters, or above and between the JJI-Joist rafters. A warm roof designs will make the entire structure of the building warm in order to avoid cold bridging (an element of the building that allows heat or energy loss).

Example Cold Roof

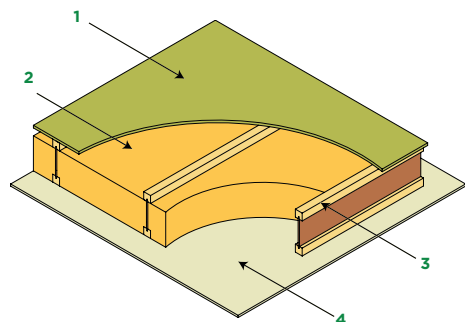

- 1. Deck/roof covering
- 2. Insulation
- 3. JJI-Joist rafter
- 4. Ceiling lining

Example Warm Roof

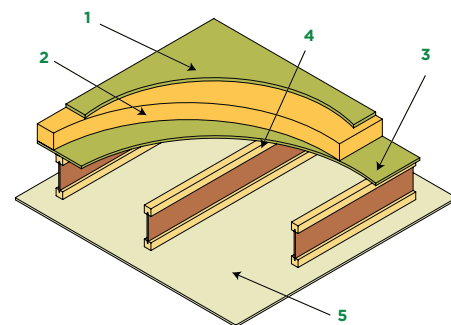

- 1. Deck/roof covering
- 2. Insulation
- 3. Vapour control layer/sub-deck
- 4. JJI-Joist rafter
- 5. Ceiling lining

JJI-Joist flat rafters

The following span table is for JJI-Joists in flat rafter applications, joists designed using the principles of Eurocode 5 limit state design code (BS EN1995-1-1).

Joist Type	Dead Load up to 0.5kN/m ²				Dead Load up to 0.75kN/m ²				Dead Load up to 1kN/m ²				Dead Load up to 1.5kN/m ²			
	Joists Centres (mm)				Joists Centres (mm)				Joists Centres (mm)				Joists Centres (mm)			
	300	400	480	600	300	400	480	600	300	400	480	600	300	400	480	600
JJI 195A+	5543	4998	4677	4307	5072	4564	4265	3920	4716	4237	3954	3627	4203	3764	3504	3203
JJI 220A+	6122	5523	5171	4765	5605	5048	4720	4342	5216	4690	4380	4022	4654	4172	3888	3559
JJI 220B+	6891	6212	5811	5350	6302	5670	5296	4866	5859	5261	4908	4500	5218	4670	4345	3970
JJI 220C	7174	6465	6046	5564	6559	5898	5507	5057	6095	5470	5101	4674	5425	4852	4512	4119
JJI 220D	8008	7209	6737	6193	7313	6567	6126	5618	6788	6083	5665	5183	6029	5381	4997	4551
JJI 235A+	6441	5813	5444	5018	5899	5315	4971	4575	5491	4940	4615	4240	4903	4398	4100	3756
JJI 235B+	7237	6526	6107	5624	6621	5960	5569	5119	6158	5533	5163	4737	5488	4915	4576	4184
JJI 235C	7542	6799	6361	5856	6898	6206	5797	5326	6413	5759	5373	4926	5712	5112	4757	4346
JJI 235D	8421	7583	7089	6520	7693	6912	6451	5919	7144	6406	5970	5465	6351	5673	5271	4806
JJI 240A+	6545	5907	5532	5100	5995	5402	5053	4651	5581	5022	4692	4311	4984	4472	4169	3820
JJI 240B+	7344	6623	6198	5710	6720	6050	5654	5198	6251	5617	5243	4811	5573	4992	4648	4251
JJI 240C	7662	6908	6463	5951	7009	6307	5892	5414	6517	5853	5461	5008	5806	5197	4837	4420
JJI 240D	8560	7709	7208	6630	7821	7029	6560	6020	7264	6515	6072	5560	6459	5771	5363	4891
JJI 245A+	6648	6001	5620	5182	6090	5488	5134	4726	5670	5102	4767	4381	5064	4545	4238	3883
JJI 245B+	7449	6719	6288	5793	6817	6138	5737	5275	6342	5700	5321	4883	5655	5067	4719	4316
JJI 245C	7781	7016	6565	6045	7119	6406	5986	5501	6620	5947	5549	5090	5899	5282	4916	4494
JJI 245D	8699	7836	7326	6740	7949	7145	6670	6122	7384	6624	6174	5654	6568	5869	5455	4976
JJI 300A+	7762	7012	6571	6063	7117	6420	6009	5537	6631	5974	5587	5140	5931	5330	4976	4567
JJI 300B+	8604	7768	7275	6709	7883	7105	6647	6119	7340	6606	6173	5674	6557	5885	5488	5030
JJI 300C	9067	8183	7662	7062	8303	7481	6996	6437	7729	6952	6494	5966	6899	6188	5768	5282
JJI 300D	10195	9192	8601	7921	9327	8394	7843	7208	8673	7792	7270	6669	7729	6920	6442	5888
JJI 350A+	8629	7799	7311	6750	7916	7146	6692	6170	7380	6654	6226	5733	6607	5944	5553	5102
JJI 350B+	9474	8558	8019	7400	8686	7835	7334	6757	8093	7291	6818	6273	7238	6505	6072	5572
JJI 350C	10261	9265	8678	8004	9402	8476	7930	7302	8756	7882	7367	6773	7823	7024	6552	6006
JJI 350D	11423	10306	9648	8891	10458	9419	8806	8100	9731	8750	8171	7503	8682	7784	7252	6638
JJI 400D	12480	11266	10551	9729	11433	10304	9638	8872	10645	9579	8950	8226	9507	8532	7956	7290

Table 17. Maximum engineering span for JJI-Joist flat rafters

Notes for Table 17:

1. This table serves as guidance only. For a more detailed JJI-Joist appraisal contact a JJI-Joist Distributor. The calculated spans are engineering spans in mm
2. This table has been calculated for cold flat roof (Service Class 2), category H (access only for maintenance)
3. Load combinations equations 6.10aSTR 6.10bSTR (EN1990) have been used in this table
4. Loads include imposed loads $q_k=0.6kN/m^2$, $Q_k=0.9kN$ and snow load $0.75kN/m^2$ No wind allowance has been considered in this table
5. The calculated spans are engineering spans for simply supported joists
6. It has been assumed that adequate lateral restraint is provided to top and bottom flanges
7. It is assumed that load can be shared between roof joists ($K_{sys}=1.1$)
8. Joists design values have been calculated using K_{mod} factors from table 3.1 (EN1995) and $v_{M,timber}=1.3$, $v_{M,OSB}=1.2$
9. Final deflection limit has been taken as $L/250$. No additional instantaneous deflection limit has been applied
10. There is no allowance for overhangs within this table
11. To achieve stated span, adequate bearing will be required. Web stiffeners may be necessary
12. Permissible web holes to be drilled in accordance to Joistmaster software
13. Standard JJI-Joist products shown within table. For non-standard JJI-Joist products (see Table 1) refer to JJI-Joist Distributor for availability

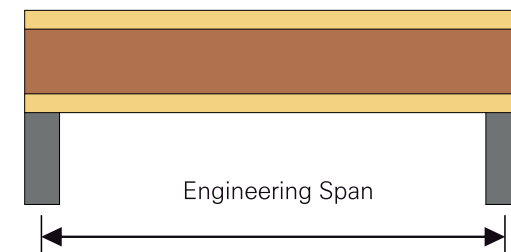

JJI-Joist pitched rafters

The following span table is for JJI-Joists in pitched rafter applications, joists designed using the principles of Eurocode 5 limit state design code (BS EN1995-1-1).

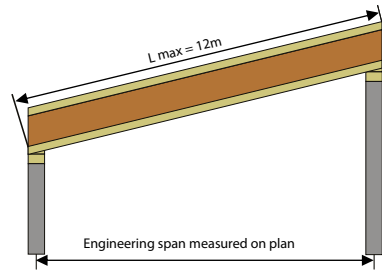

Support requirements

When designing a JJI-Joist pitched rafter the designer should ensure that there are at least two vertical supports under the rafter. Typically these would be a load bearing wall or ridge beam at the top end and a load bearing wall at the lower end. Additional intermediate supports may be provided by, for example, purlins. It is possible to design the JJI-Joist rafters with only one support at the lower end if the top end (Ridge) is resting on another rafter leaning in the opposite direction. This, however, leads to horizontal reactions at the lower end and higher axial loads that need to be considered by a Structural Engineer.

Joist Type	Dead Load up to 0.5kN/m ²			Dead Load up to 1kN/m ²			Dead Load up to 0.5kN/m ²			Dead Load up to 1kN/m ²		
	400mm centres						600mm centres					
	Joists Centres (mm)			Joists Centres (mm)			Joists Centres (mm)			Joists Centres (mm)		
	15°	30°	45°	15°	30°	45°	15°	30°	45°	15°	30°	45°
JJI 195A+	4916	4660	4205	4161	3927	3516	4238	4022	3636	3564	3370	3025
JJI 220A+	5431	5148	4643	4606	4345	3888	4688	4447	4018	3952	3733	3349
JJI 220B+	6109	5792	5228	5168	4878	4369	5264	4997	4519	4422	4182	3756
JJI 220C	6359	6029	5444	5373	5073	4546	5475	5199	4703	4594	4346	3905
JJI 220D	7092	6728	6079	5976	5646	5065	6095	5791	5245	5095	4825	4342
JJI 235A+	5716	5416	4884	4851	4575	4093	4936	4682	4229	4165	3934	3527
JJI 235B+	6418	6084	5489	5433	5129	4591	5534	5252	4748	4655	4400	3950
JJI 235C	6687	6339	5722	5656	5340	4782	5762	5470	4946	4841	4578	4111
JJI 235D	7459	7075	6391	6293	5945	5330	6417	6094	5517	5372	5084	4573
JJI 240A+	5809	5504	4962	4931	4651	4159	5017	4759	4298	4235	4000	3586
JJI 240B+	6513	6174	5571	5516	5206	4661	5617	5330	4818	4727	4469	4010
JJI 240C	6793	6441	5813	5748	5427	4859	5855	5558	5025	4921	4653	4178
JJI 240D	7583	7192	6496	6400	6045	5419	6524	6196	5609	5465	5172	4651
JJI 245A+	5901	5590	5040	5009	4725	4225	5097	4834	4366	4304	4064	3643
JJI 245B+	6607	6262	5650	5598	5282	4728	5699	5408	4888	4798	4535	4069
JJI 245C	6900	6541	5903	5840	5512	4936	5948	5646	5104	5002	4728	4245
JJI 245D	7707	7310	6602	6506	6145	5508	6632	6299	5701	5558	5259	4728
JJI 300A+	6894	6530	5884	5864	5529	4940	5963	5653	5101	5048	4765	4266
JJI 300B+	7638	7237	6524	6486	6117	5469	6598	6258	5650	5573	5264	4717
JJI 300C	8046	7624	6876	6826	6440	5760	6947	6590	5952	5860	5537	4964
JJI 300D	9040	8570	7734	7652	7223	6467	7793	7397	6688	6554	6196	5562
JJI 350A+	7668	7260	6539	6531	6155	5496	6638	6290	5673	5629	5310	4752
JJI 350B+	8414	7969	7181	7158	6747	6029	7277	6899	6225	6161	5814	5206
JJI 350C	9110	8630	7780	7739	7298	6524	7872	7465	6739	6652	6281	5628
JJI 350D	10134	9604	8663	8592	8107	7254	8746	8297	7497	7371	6965	6247
JJI 400D	11078	10496	9463	9405	8871	7933	9569	9076	8195	8080	7631	6840

Table 18. Maximum engineering span for JJI-Joist pitched rafters (400 and 600 centers)

Notes for Table 18.

- This table serves as guidance only. For a more detailed JJI-Joist appraisal contact a JJI-Joist Distributor. The calculated spans are engineering spans in mm
- This table has been calculated for cold pitched roof (Service Class 2), category H (access only for maintenance)
- Load combinations equations 6.10aSTR 6.10bSTR (EN1990) have been used in this table
- Loads for roof with 15° and 30° pitch include imposed loads $q_k=0.6kN/m^2$, $Q_k=0.9kN$ and snow load $0.75kN/m^2$
- Loads for roof with 45° pitch include imposed loads $q_k=0.3kN/m^2$, $Q_k=0.9kN$ and snow load $0.75kN/m^2$
- No wind allowance has been considered in this table
- The calculated spans are engineering spans measured on plan for simply supported joists

- It has been assumed that adequate lateral restraint is provided to top and bottom flanges
- It is assumed that load can be shared between roof joists ($K_{sys}=1.1$)
- Joists design values have been calculated using K_{mod} factors from table 3.1 (EN1995) and $\gamma_{M,timber}=1.3$, $\gamma_{M,OSB}=1.2$
- Final deflection limit has been taken as $L/250$. No additional instantaneous deflection limit has been applied
- There is no allowance for overhangs within this table
- To achieve stated span, adequate bearing will be required. Web stiffeners may be necessary
- Permissible web holes to be drilled in accordance to Joistmaster software
- Standard JJI-Joist products shown within table. For non-standard JJI-Joist products (see Table 1) refer to JJI-Joist Distributor for availability

Example of JJI-Joist roof system

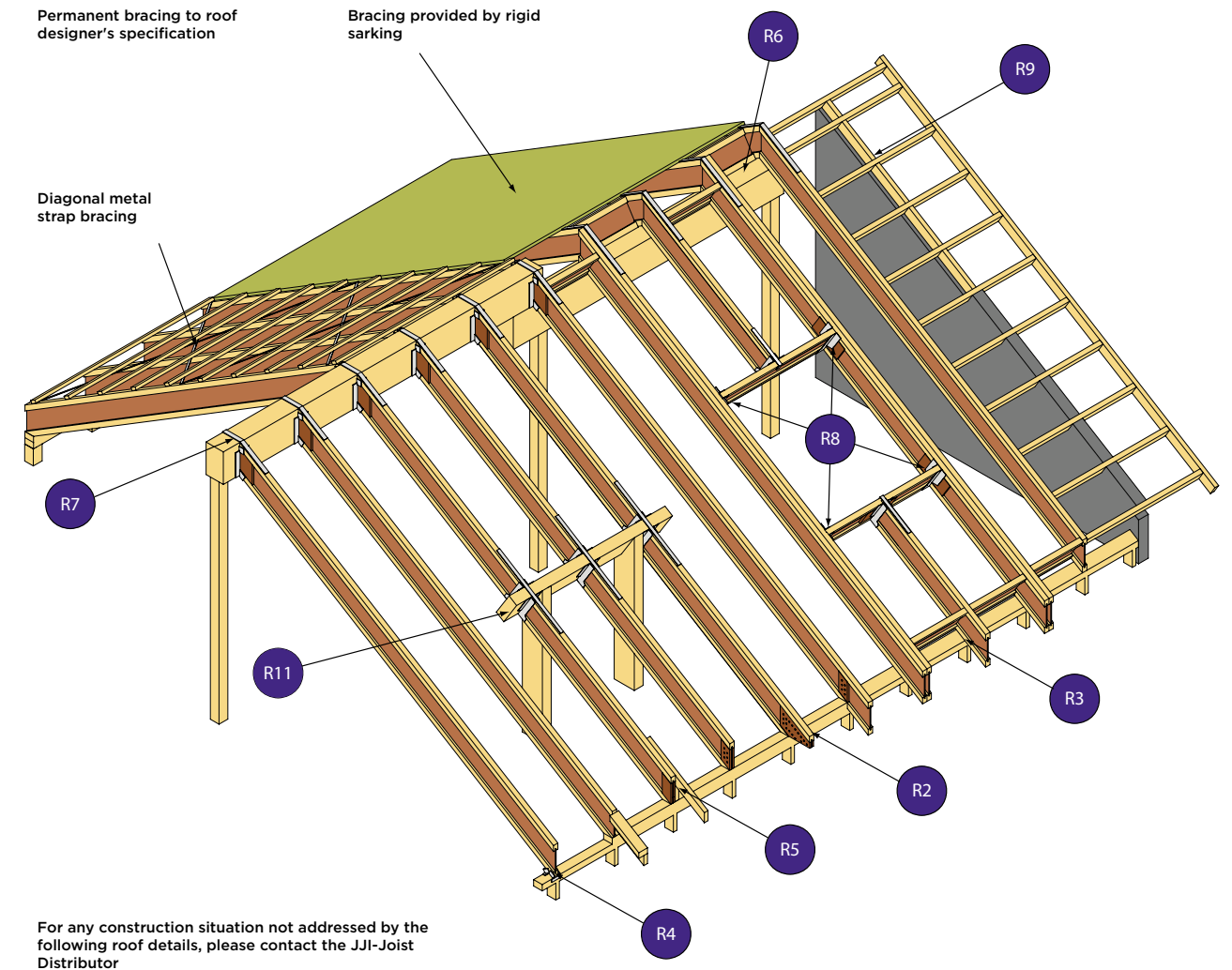

For any construction situation not addressed by the following roof details, please contact the JJI-Joist Distributor

R1 - JJI-JOIST BEARING LENGTHS

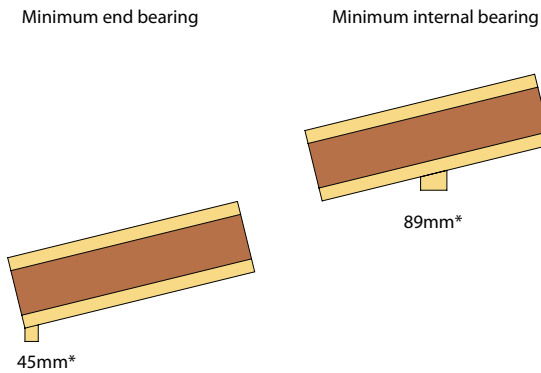

* Minimum bearing required by JOIST DESIGN. Consult building/roof designer for building stability requirements

R2 - BIRDSMOUTH CUT

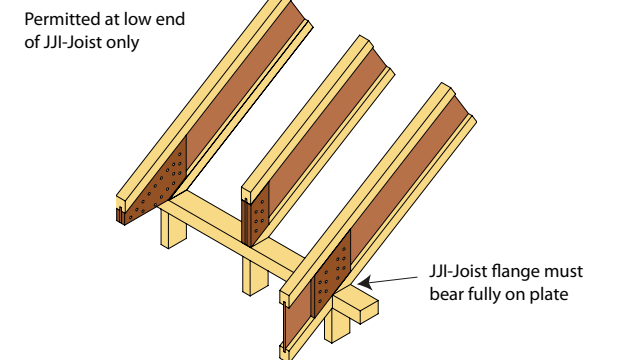

Bevelled ply/timber web stiffener each side of JJI-Joist web. Fix in accordance with detail F22. Do not bevel cut the JJI-Joist past the inside face of wall. Blocking omitted for clarity

R3 - BEVELLED SUPPORT PLATE FOR PITCHES UP TO 45°

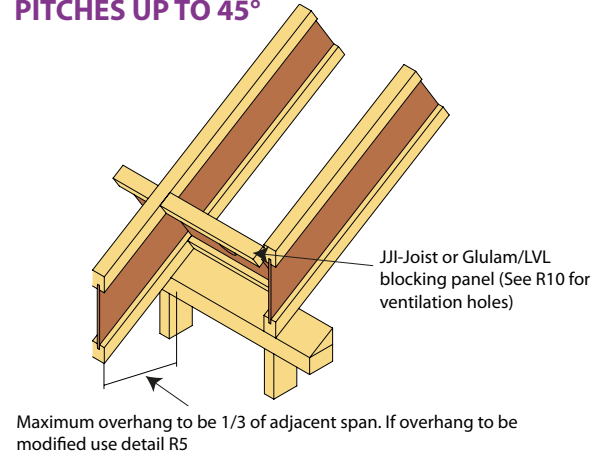

R4 - ADJUSTABLE SEAT CONNECTOR FOR PITCHES 15°-45°

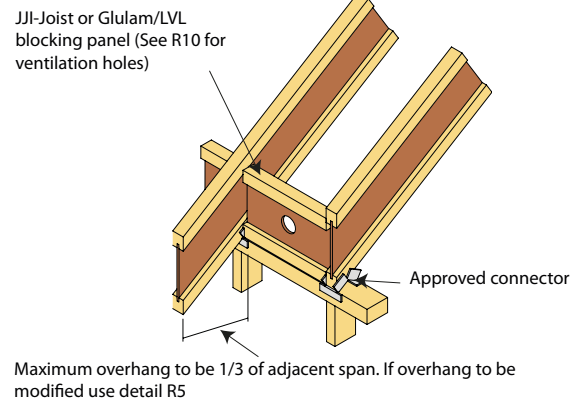

R5 - LOOSE TIMBER OVERHANGS

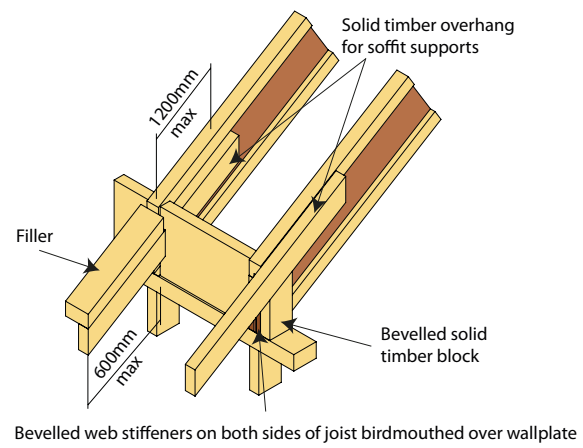

R6 - DOWNSTAND RIDGE BEAM

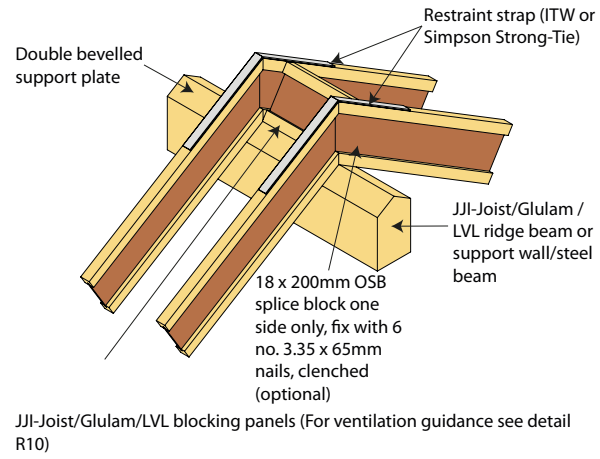

R9 - GABLE LADDER

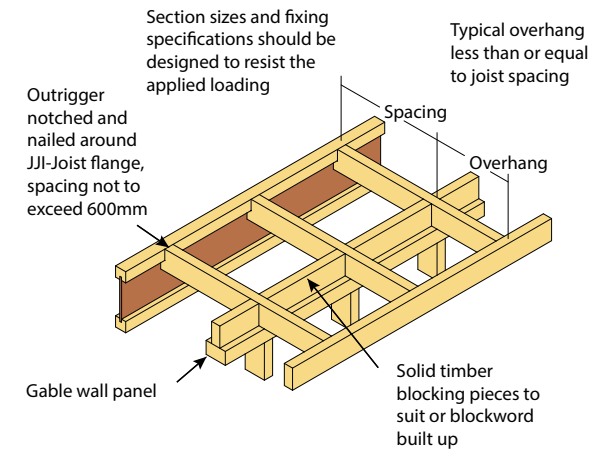

R10 - BLOCKING AND VENTILATION HOLES

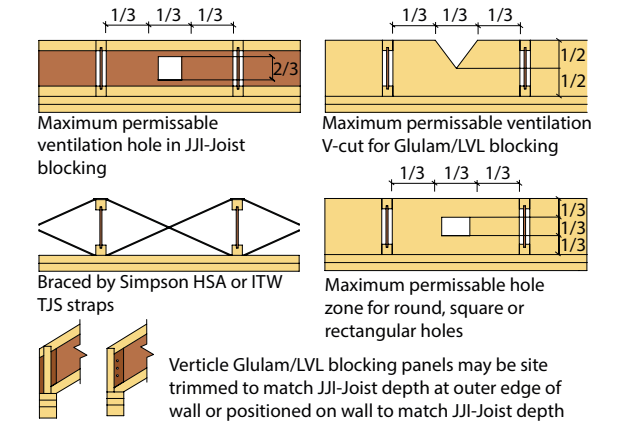

R11 - FLUSH PURLIN BEAM

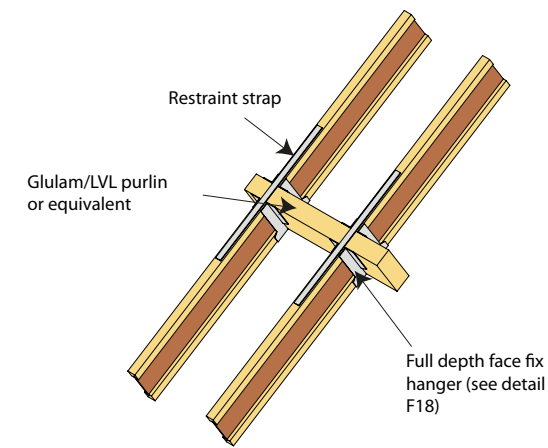

R12 - JJI-JOIST RAFTER FIXING TO WALL PLATE

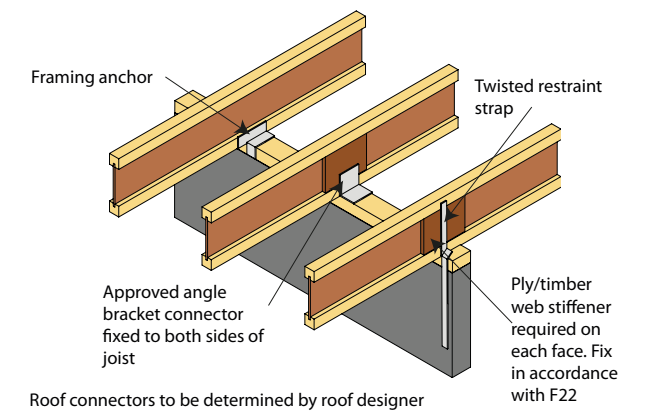

R7 - FLUSH RIDGE BEAM

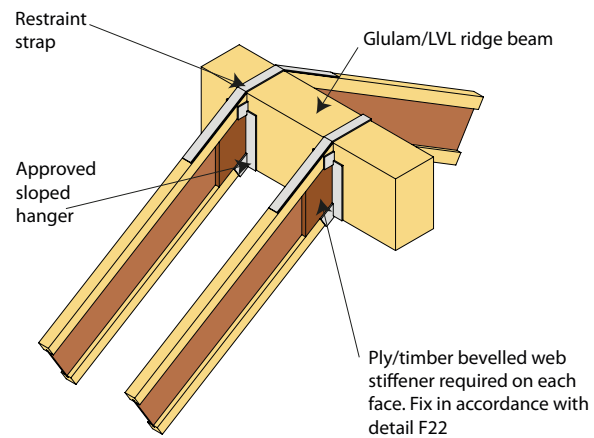

R8 - OPENING IN ROOF

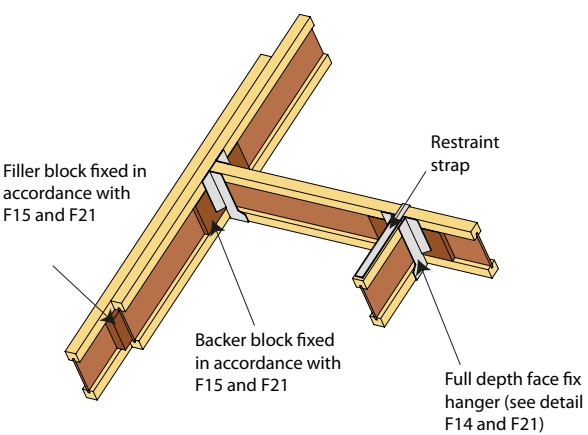

R13 - JJI-JOIST RAFTER TERMINATING ON DOWNSTAND RIDGE BEAM

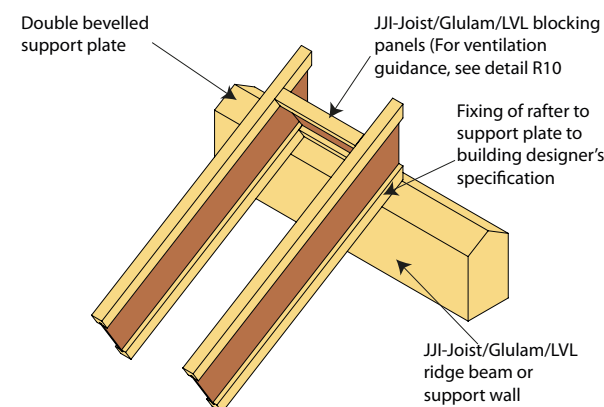

R14 - JJI-JOIST RAFTER TERMINATING ON DOWNSTAND STEEL BEAM

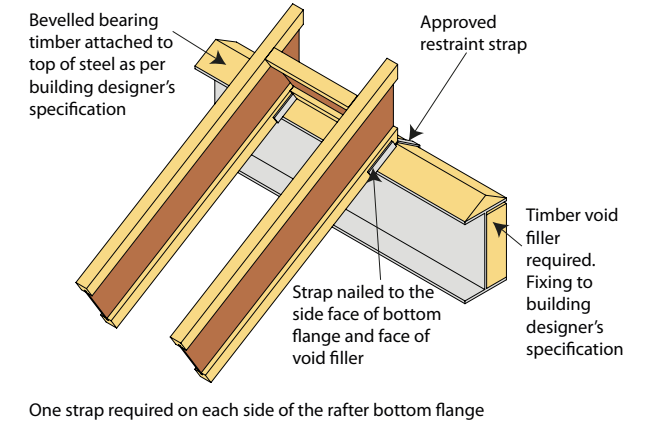

SECTION 6 WALL DESIGN



JJI Wall Studs

JJI-Joists are ideally suited for use as wall studs where their availability in depths up to 300mm allows designers to insulate external walls to unprecedented levels. Even when shallower joists are used the narrow web profile provides a restricted path to heat transfer (reduced repeated thermal bridging) when compared with solid timber.

DESIGN CONSIDERATIONS



Image courtesy of Touchwood Homes

Design considerations

Where the wall is subjected only to horizontal wind loads with no vertical axial loads (e.g. ground level to eaves level infill panels in a portal frame structure) JJI-Joists allow very tall walls to be built using a continuous structural member.

James Jones and Sons recommend that JJI-Joists are incorporated into prefabricated wall panels in order to take advantage of the improved precision and quality typically available in a factory environment. Each timber frame kit manufacturer will typically produce their own set of standard details to suit their specific production, manufacturing and technical requirements.

The structural design of JJI-Joist studs should be undertaken by a Structural Engineer who should pay particular attention to buckling restraint, axial load distribution between inner and outer flanges and member to member fixings. For further information on axial compression strengths please contact James Jones and Sons.

It is our recommendation that the use of JJI-Joist studs is best suited to external wall closed panel type manufacturing with a separate service zone on the inside face of the internal sheathing. The lightweight nature of JJI-Joists permits the construction of larger panels than might otherwise be possible reducing the number of site lifts required.

Particular care should be taken when insulating to avoid cold spots.

2022 changes to Part L of the Building Regulations which took effect on 15th June 2023, require significant increases in thermal performance.

JJI-Joist wall studs can be used to meet these requirements.



Image courtesy of Roel Reuben



Image courtesy of Touchwood Homes

Thermal performance of JJI-Joists used in the external envelope of a building

There are many possible ways to utilise JJI-Joists in the external envelope of a building. The thermal and condensation performance of any chosen configuration and material combination should be assessed by a suitably qualified person.

The U-Value of a detail is highly dependant on the quality of the insulation material used. The key property of the insulation in this respect is the conductivity (λ - Value) which varies from material to material and across different forms and densities of the same material. A selection of common insulation materials is provided below showing the range of λ - Values indicated in the manufacturer's literature.

Conductivity (λ -values) for some common insulation materials

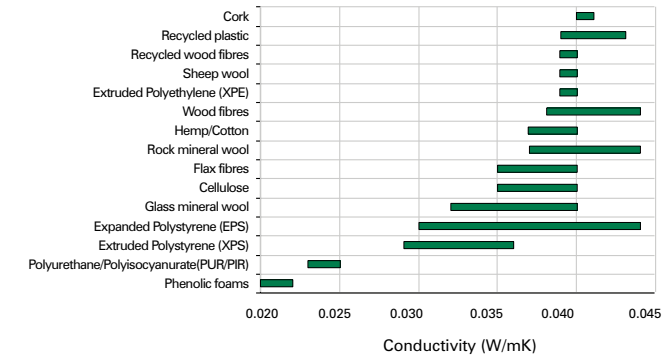

Notes:

1. Values shown were obtained from a review of publicly available product information
2. List of materials is not intended to be exhaustive
3. These materials can be purchased in different forms (e.g. slabs, batt, roll, loose, etc)
4. Always refer to manufacturer's published data

The adjacent illustration details the heat transference through a typical JJI-Joist stud wall, construction as shown top right.

Whilst it can be seen that the JJI-Joist web conducts more heat than the surrounding insulation, the limited cross section of the 9mm OSB web, when compared to a typical solid timber stud, greatly reduces repeated thermal bridging.

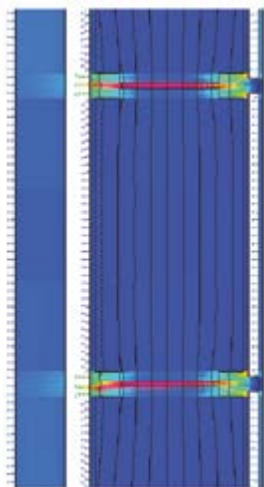

Typical JJI-Joist stud external timber frame wall

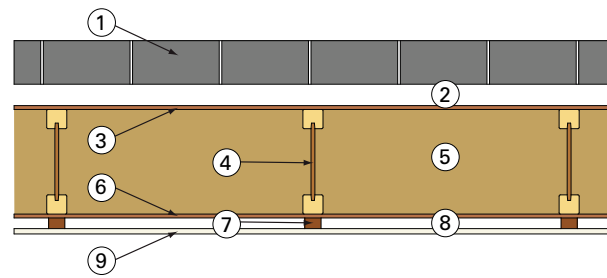

1. Masonry 100mm
 2. Air Cavity 50mm
 3. Wood based board 9mm
 4. JJI-Joist Stud
 5. Insulation material
 6. Wood based board 9mm
 7. Softwood batten 38 x 25
 8. Service void
 9. Plasterboard 12.5mm
- Note: Vapour barriers, breather paper and wall ties omitted for clarity**

The graph below can be used to relate the U-Value for a wall based on its thickness (JJI-Joist depth) and λ - Value of the chosen insulation

Indicative U-Values for typical JJI-Joist Stud External Wall

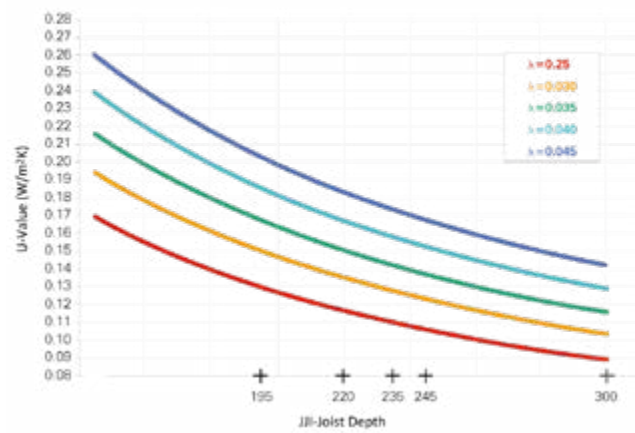

Notes:

1. U-Values are calculated for the typical JJI-stud external wall detail (see above)
2. All U-Values have been calculated according to BS EN ISO 6946
3. JJI A+ studs at 600mm centres
4. Insulation is assumed to completely fill the JJI-Joist web void
5. Conductivity (λ -Values) are given in W/mK

For further information on thermal performance of JJI-Joists structures please contact James Jones and Sons.

W1 - GROUND FLOOR TO WALL JUNCTION

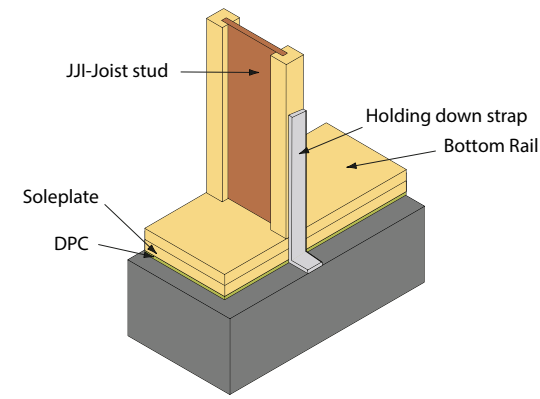

W2 - INTERMEDIATE FLOOR TO WALL JUNCTION

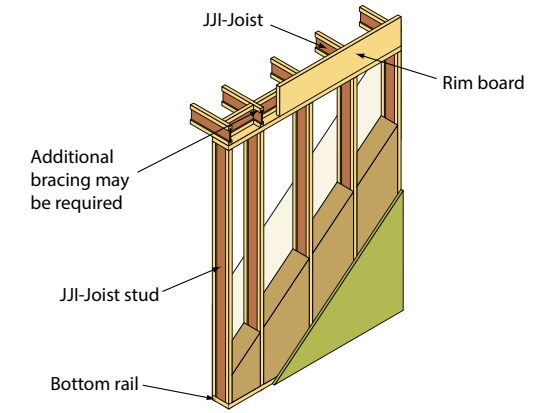

W3 - EXTERNAL WALL CORNER JUNCTION

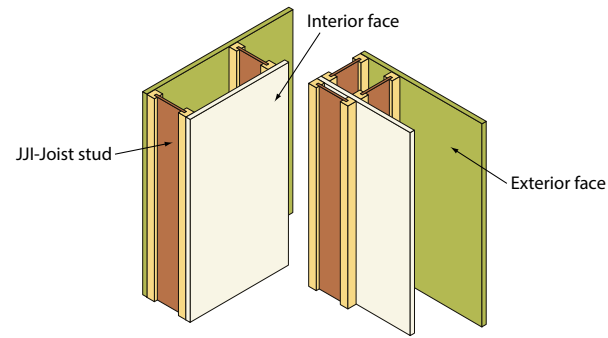

W4 - EXTERNAL WALL INVERTED CORNER

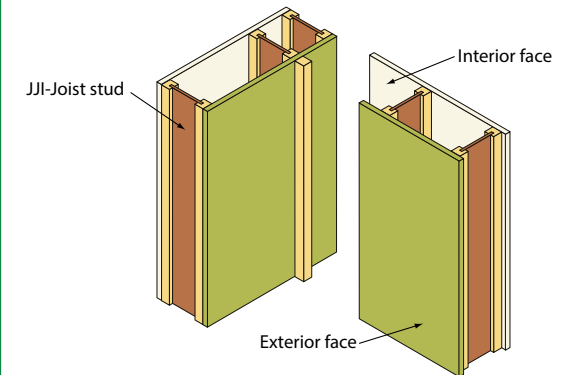

W5 - STRUCTURAL OPENING

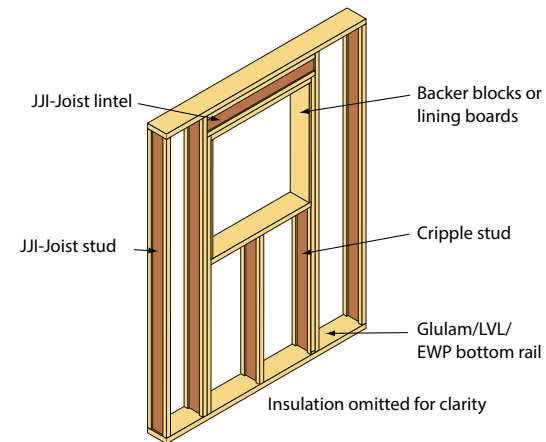

W6 - INTERNAL TO EXTERNAL WALL JUNCTION

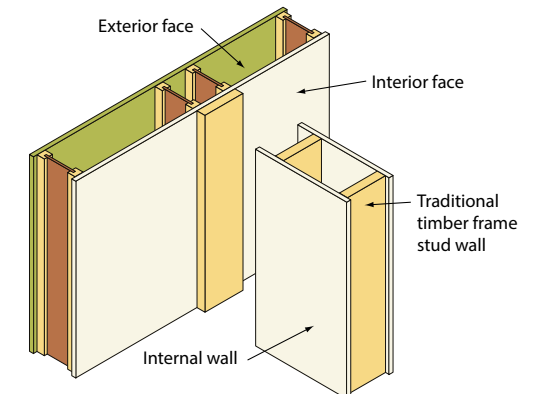





James Jones
& SONS LIMITED
TIMBER SYSTEMS DIVISION

Our timber systems division is the UK's largest manufacturer of certified i-joists, branded as JJI-Joists.

Greshop Industrial Estate, Forres, Moray. IV36 2GW.
01309 67111

